

Three Phase Multifunction Network Power Meter

User Manual

E12ZY

Contents

1.Product brief introduction	1
2.Function introduction	2
3.Technical parameter	3
4.Installation and Wiring	4
5.Programme operation	8
6.Panel explain and measurement information display	12
7.Communication Protocol	22
8.Function Output	35
9.Ordinary problem and solution	39

1. Product Brief introduction

1.1 Standard

Reference standard

GB/T 17883-1999 Class 0.2S and 0.5s Static AC Active Electric Meter

GB/T 17882-1999 Class 2 and 3 Static AC Reactive Electric Meter

DL/T 614 Multifunction Electric Power Meter

GB/T 13850 Ac Energy Transfer to Analog Quantity or Electric Measuring Transmitter of Digital Signal.

Performance Standard:

GB/T 22264.1- Panel Type Digital Display Electric Measuring Instrument, Part 1: Definition and General Requirement.

GB/T 22264.2- Panel Type Digital Display Electric Measuring Instrument, Part 2: Special Requirements for Current Meter and Voltage meter.

GB/T 22264.3- Panel Type Digital Display Electric Measuring Instrument, Part 3: Special requirements for power meter and reactive power meter.

GB/T 22264.4- Panel Type Digital Display Electric Measuring Instrument, Part 4: Special requirements for frequency meter.

GB/T 22264.5- Panel Type Digital Display Electric Measuring Instrument, Part 5: Special requirement for phase meter and power factor meter

GB/T 22264.7- Panel Type Digital Display Electric Measuring Instrument, Part 7: Define and General requirement.

GB/T 22264.8-Panel Type Digital Display Electric Measuring Instrument, Part 8: Commend test way.

1.2 Product Overview

Three phase multifunction network power meter which provided with high ability and precision can measure all electrical parameters in three phase electric network, include three phase voltage, three phase current, active power, reactive power, apparent power, frequency, power factor, four-quadrant energy, UIPQ demand quantity, time-sharing accounting, switching input monitoring, electric pulse output and with communication interface.

The product is provided with many extended function of input and output for choosing:1 communication interface, 3 oops of transmitting output, local or remote switch signal output,3 loops of switch monitoring, 2 loops electric pulse output.

The product is with best competitive, can directly replace with general power transmitted, measuring meter, power energy measure meter and relative auxiliary unit, can widely apply to many fields, like energy manage system, power monitor system, industry and mining enterprise, public place, intelligent building and switch board those power net system, SGADA system and so on. The product is provided with many advantages such as simple installation, simple wiring, convenient maintenance, less engineering work, programming on the spot and it can complete different communication software network for PLC, industry control.

2. Function Introduction (See Table 1)

Table 1

Measurement function		Remark
Real-time measurement	Three phase voltage	Basic function
	Three phase current	
	Power, Frequency, Power factor	
Energy measurement	Active energy	
	Reactive energy	
	Two-way measurement	
Switching input	Passive dry contact point	Extended function
Switching output	AC250V 5A remote/alarm	
Communication	RS485 interface MODBUS-RTU	
Display mode		LED display, LCD display

3. Technical parameter (See Table 2)

Table 2

Item		Parameter	
Signal input	Wiring	3 phase 4 lines/3 phase 3 lines	
	Voltage	Measurement range	AC(50~500)V
		Over load	Continuous: 1.2 multiple, instantaneous: 2 multiple/1s
		Power consumption	<1VA (per phase)
	Current	Measurement range	AC(50mA~5A)
		Over load	Continuous: 1.2 multiple, instantaneous: 10 multiple/5s
		Power consumption	<0.4VA (per phase)
Frequency	45~65Hz		
Power supply	AC220V,AC 85~265V,DC 100~300V ≤5VA		
Communication	RS485 communication interface, physical layer isolation. Meet the international standard of MODBUS-RTU agreement Communication speed 1200~38400 Test type N81,E81,081		
Switching output	Programmable remote/alarm switching output Capacity: 5A/250VAC 5A/30VDC Programmable alarm power or remote mode		
Remote switch	Remote switch input measuring, passive dry contact input, programmable relate alarm output		
Measurement class	Power: 0.5 Frequency: ±0.2Hz Active power: 1.0 Reactive power: 2.0		
Display mode	LED display, LCD display		
Environment	Working temperature: -10~+45°C Storage temperature: -25~+50°C Relative humidity: <85%RH		
Safety	Isolation:resistance of Signal input, power source and output terminal to cover>100MΩ Withstand Voltage:Signal Input/power supply , Power Supply/Signal output :AC 2kV, Signal Input/Signal Output:1kV		
Protection grade	Front panel: IP52		

Three Phase Multifunction Network Power Meter

4. Installation and Wiring

4.1 Panel Size(mm): 96×96 Hole Size(mm): 91×91 Depth(mm): 60 (See Fig.1)

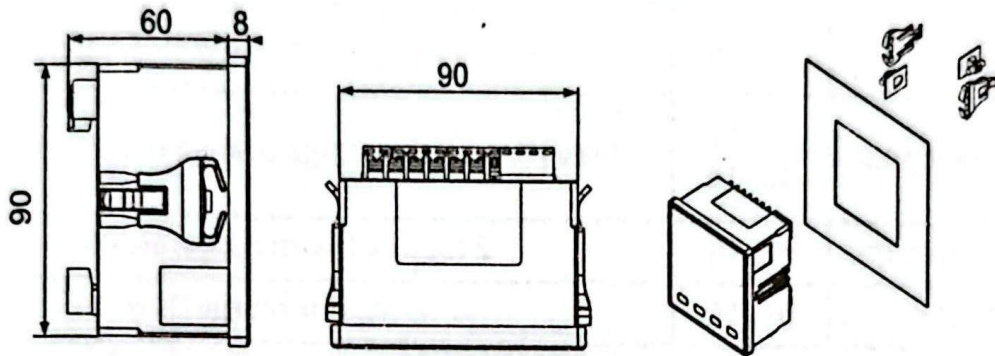

Fig.1

4.2 Panel Size(mm): 80×80 Hole Size(mm): 76×76 Depth(mm): 71 (See Fig.2)

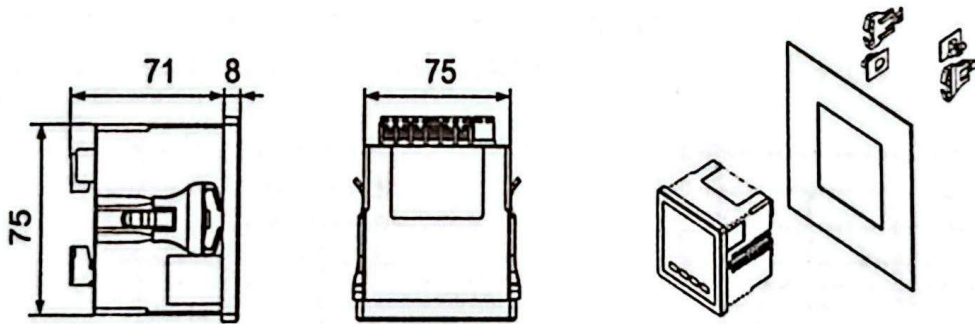

Fig.2

4.3 Panel Size(mm): 72×72 Hole Size(mm): 67×67 Depth(mm): 71 (See Fig.3)

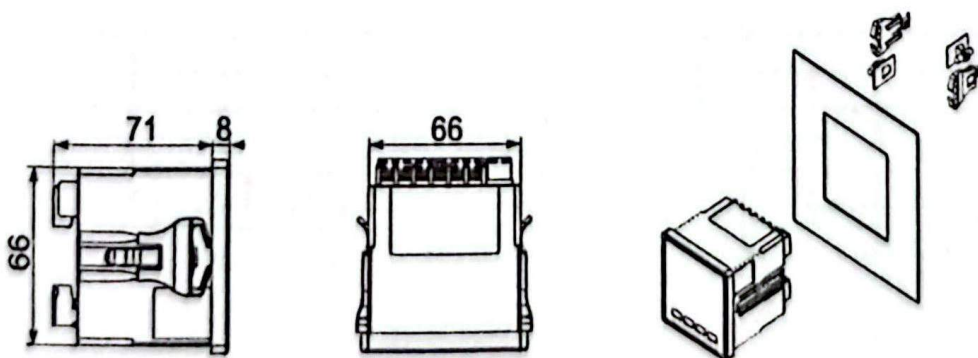

Fig.3

4.4 Wiring terminal function (see Table 3)

Table 3

Power supply	1, 2	AC85-265V, AC220V
Current signal	4, 5, 6 7, 8, 9	No.4,6,8 are the terminal of current signal input No.5,7,9 are the terminal of current signal output
Voltage signal	11, 12 13, 14	Three phase Voltage signal input is Ua, Ub,Uc,Un
Switching output	15-18	2 loops of switching output
RS485	58, 59	A, B terminal
Switching input	70-74	4 loops of switching input, 70 is the common terminal

Three Phase Multifunction Network Power Meter

Instructions for use

- (a) 1, 2 is the auxiliary power supply terminal for meter working, please make sure the supply power is suitable for this product to avoid damaging product.
- (b) 4,6,8 is the input terminal of current transformer, with* signal is for the input terminal of current.
- (c) Three phase three lines connection: Current of B phase no need connection, UB connect to NO.14 terminal. Refer to 4.4 wiring.
- (d) Product connection refer to the wiring diagram printed on the product cover.

4.5 Wiring (see Fig.4 and Fig.5)

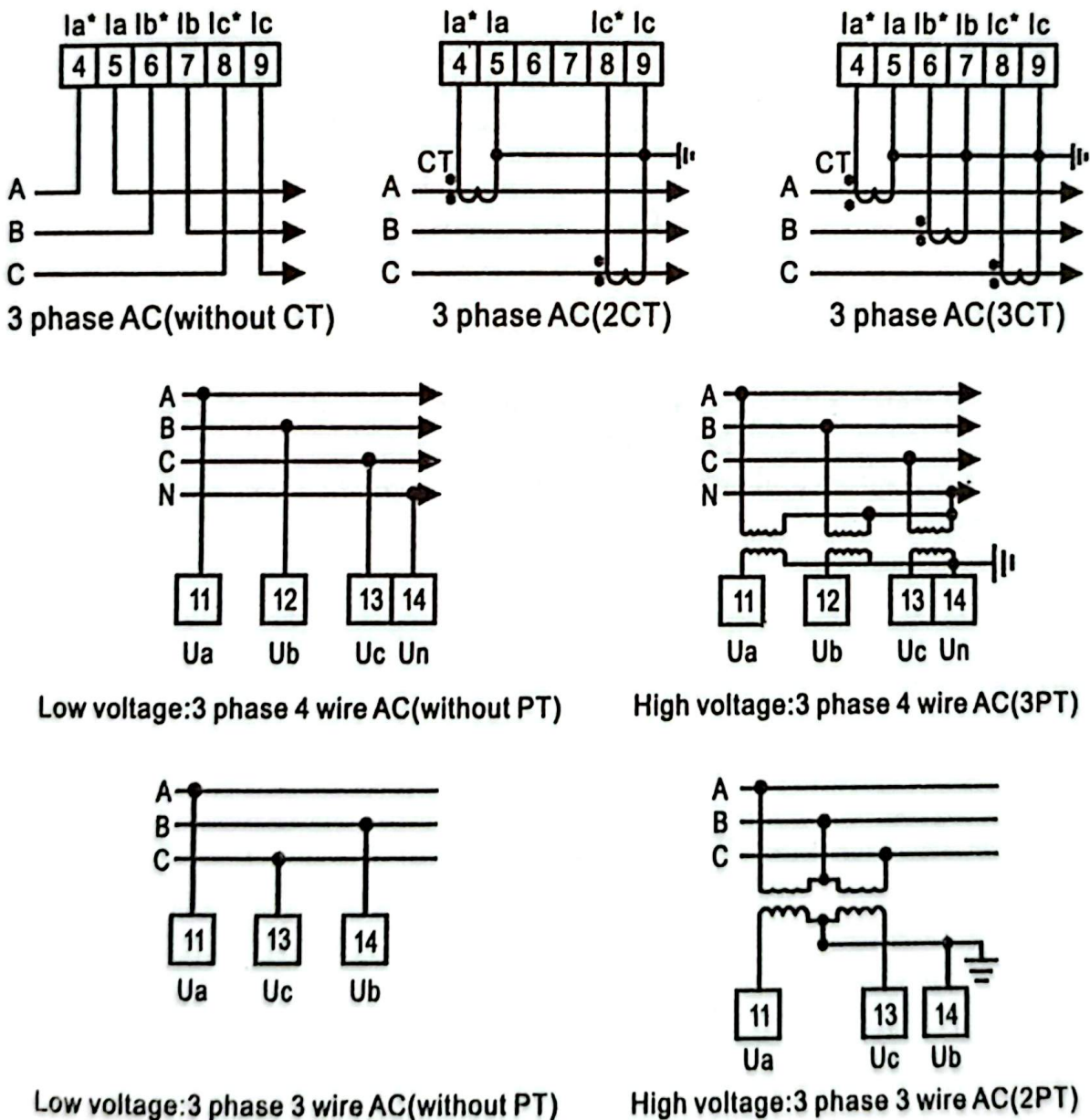

Fig.4

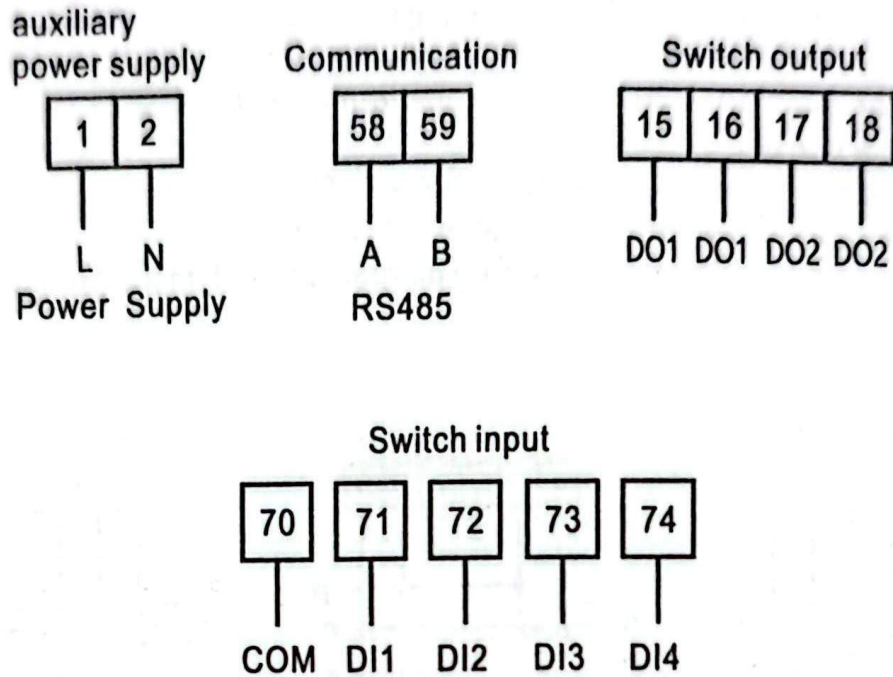

Fig.5

Note: The meter is provided with two kinds of wiring modes, please make sure the actual wiring is same to the set wiring in the meter. The wiring diagram and technical parameter printed on the product shall be prevailed.

5. Programme operation

Under programming status, digital interface adopts layered structure menu type ,meter supply three lines digital display. (see Fig.6)

No.1 line is first layer menu information.

No.2 line is second layer menu information,

No.3 line is third layer menu information.

For example: as shown in Fig. 6, No.1 line: INPT means signal input.

No.2 line:CT current ratio No. 3 line: 5 means the CT value. $CT\ value = 25/5A = 5$.

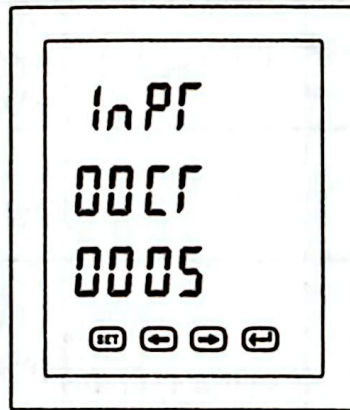

Fig.6

Parameter setting can be customized according to requirements.(See Table 4)

Table 4

No.1 layer	No.2 layer	No.3 layer	Description
System set "SET"	Display DISP	0000-0014	0000 means automatic cycling display(Displayed information see Table 5,6)
	DISL	0001-0003 or 0000-0120	0001-0003 is for LED brightness adjustment. 0000-0120 is keeping time of LCD back light(0000 means the backlight keeping ON)
	Energy clear CLr.E	1111	1111 means the energy clear, other values are invalid

Three Phase Multifunction Network Power Meter

Signal input INPT	Wiring mode NET	0000 or other values	0000 means 3 phase 4 line, other values means 3 phase 3 line
	Voltage transformation ratio PT	1~9999	PT value= PT primary value/ secondary value
	Current transformation ratio CT	1~9999	CT value= CT primary value/ secondary value
Communication set CONi (i is 1~2)	address SN	1~247	Meter address range: 1-247
	Communication speed BAUD	0001~0006	0001 means 1200; 0002 means 2400; 0003 means 4800; 0004 means 9600; 0005 means 19200; 0006 means 38400
	Data format DATA	0000~0002	0000:E,8,1; 0001:0,8,1; 0002:N,8,1
Switching output set DO-i (i is 1-4)	Choose alarm item or close alarm (refer to 8.2 switching output)	Set the specific threshold value of alarm item	Choose alarm item, and set relative threshold value (when alarm item is switching value, noneed set threshold value), once meet the alarm conditions, switch output ON.

Note: The above menu is applied to the product with complete function. If you find there is no such menu in the product or the menu is not working, it means the product not supporting the function.

Three Phase Multifunction Network Power Meter

Programming step(see Fig.7)

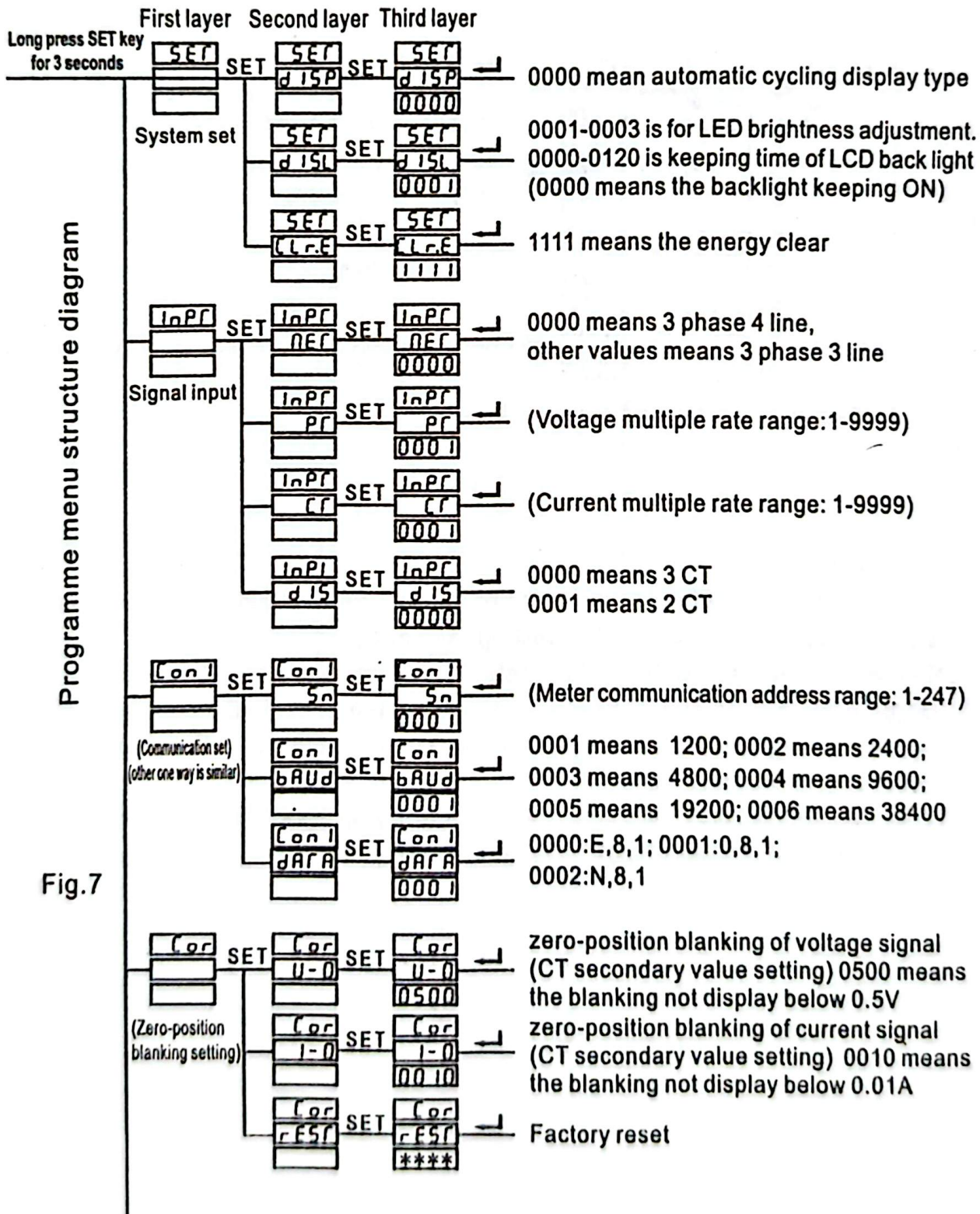

Fig.7

Continued

6. Panel explain and measurement information display

6.1 72×72,80×80,96×96 LCD display (see Fig.8)

(1) Panel instructions

If there is no relative symbol display (or the set data not working), It means the product is without the relative function.

Fig.8

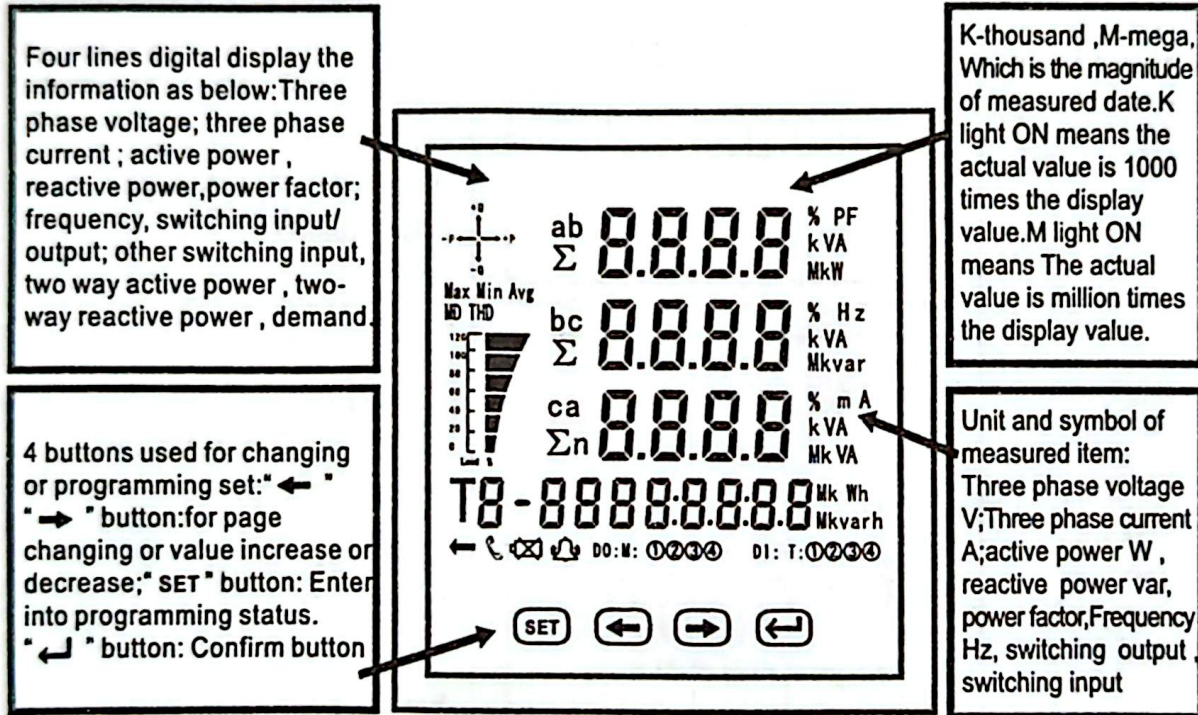

(2) The contents of displayed page (see Table 5)

Table 5

Page	Content	Explanation
DISP=1 Positive active energy of three phase voltage		<p>Separately display the voltage U_a, U_b, U_c (3 phase 4 line), positive active energy.</p> <p>In left Fig U_a=5774V U_b=5774V U_c=5774V Positive active energy =2908,05kWh</p>

Table 5

<p>DISP=2 Negative active energy of three phase voltage</p>	 <p>The meter display shows three phase line voltages: ab = 10.00 kV, bc = 10.00 kV, and ca = 10.00 kV. Below these, the negative active energy is displayed as -001000.02 kWh. The display includes a bar graph on the left and navigation buttons (SET, left, right, and a combined left-right button) at the bottom.</p>	<p>Separately display the voltage U_{ab}, U_{bc}, U_{ca} (line voltage), negative active energy.</p> <p>In left Fig $U_{ab}=10\text{kV}$ $U_{bc}=10\text{kV}$ $U_{ca}=10\text{kV}$ Negative active energy =1000.02kWh</p>
<p>DISP=3 Positive reactive energy of three phase current</p>	 <p>The meter display shows three phase currents: a = 5.000 A, b = 5.000 A, and c = 5.000 A. Below these, the positive reactive energy is displayed as 000050.00 kvarh. The display includes a bar graph on the left and navigation buttons (SET, left, right, and a combined left-right button) at the bottom.</p>	<p>Display 3-phase current I_a, I_b, I_c, the unit is A. Positive reactive energy</p> <p>In left Fig $I_a=5\text{A}$ $I_b=5\text{A}$ $I_c=5\text{A}$ Positive reactive energy =50.00kvarh</p>
<p>DISP=4 Total active power Total reactive power Total apparent power Negative reactive power</p>	 <p>The meter display shows summary power values: Total active power Σ = 86.60 kW, Total reactive power Σ = 0000 kvar, Total apparent power Σ = 86.60 kVA, and Negative reactive power T = -000100.08 kvarh. The display includes a bar graph on the left and navigation buttons (SET, left, right, and a combined left-right button) at the bottom.</p>	<p>Total active power =86.60kW Total reactive power =0000kvar Total apparent power =86.60kVA Negative reactive power =100.08kvarh</p>

Table 5

<p>DISP=5 A phase active power A phase reactive power A phase apparent power Positive active power</p>		<p>A phase active power =28.87kW A phase reactive power =0000kvar A phase apparent power =28.87kVA Positive active power =2908.05kWh</p>
<p>DISP=6 B phase active power B phase reactive power B phase apparent power Negative active power</p>		<p>B phase active power =28.87kW B phase reactive power =0000kvar B phase apparent power =28.87kVA Negative active power =1000.02kWh</p>
<p>DISP=7 C phase active power C phase reactive power C phase apparent power Positive reactive power</p>		<p>C phase active power =28.87kW C phase reactive power =0000kvar C phase apparent power =28.87kVA Positive reactive power =50.00kvarh</p>

Table 5

<p>DISP=8 Average current Zero-sequence current</p>	 <p>The LCD display shows four rows of data: 01.00% (top), 5.000 A (second), 01.00% (third), and -000050.00 kvarh (bottom). A bar graph on the left indicates a level of approximately 1. Below the display are four control buttons: SET, left arrow, right arrow, and a combined left/right arrow.</p>	<p>Displayed in left Fig Average current=5A Zero-sequence current=0.006A</p>
<p>DISP=9 Three phase total power factor, Frequency, Voltage unbalance</p>	 <p>The LCD display shows four rows of data: 1.000 PF (top), 50.00 Hz (second), 0009 V (third), and 002908.05 kWh (bottom). A bar graph on the left indicates a level of approximately 1. Below the display are four control buttons: SET, left arrow, right arrow, and a combined left/right arrow.</p>	<p>Displayed in left Fig Three phase total power factor =1.000 Frequency=50Hz Voltage unbalance=9V positive phase active energy =2908.05kWh</p>
<p>DISP=10 Power factor for each phase</p>	 <p>The LCD display shows four rows of data: a 0.999 PF (top), b 0.999 PF (second), c 0.999 PF (third), and -001000.02 kWh (bottom). A bar graph on the left indicates a level of approximately 1. Below the display are four control buttons: SET, left arrow, right arrow, and a combined left/right arrow.</p>	<p>Displayed in left Fig A phase power factor =0.999 B phase power factor =0.999 C phase power factor =0.999 Negative active energy =1000.02kWh</p>

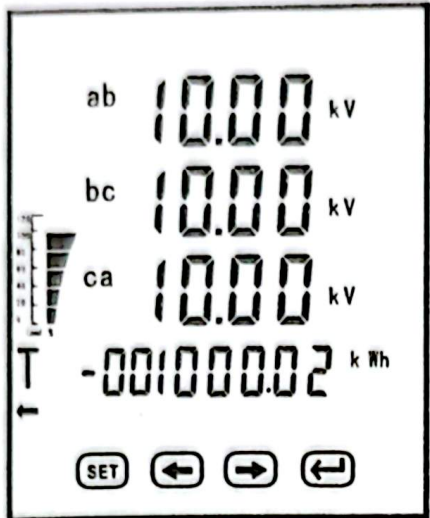
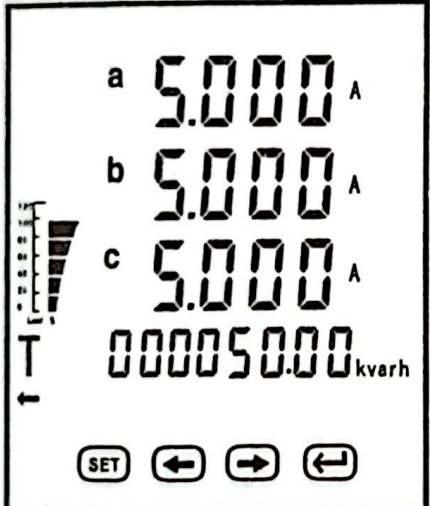
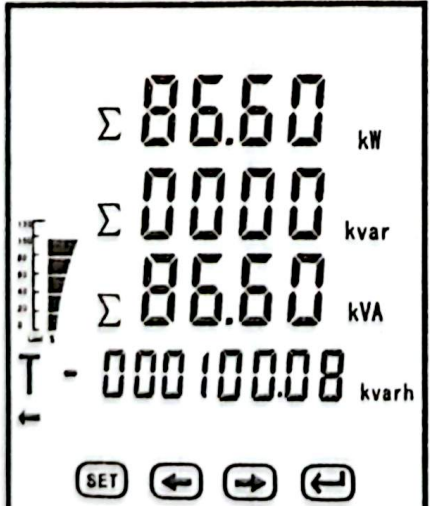
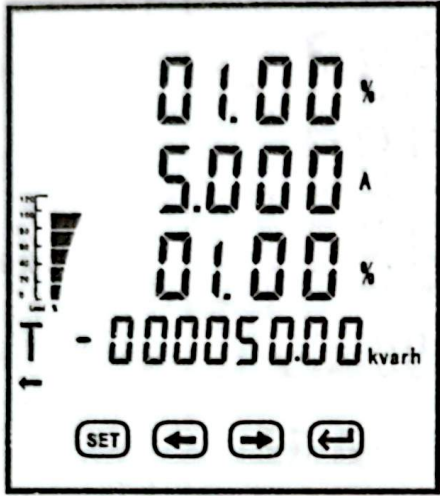
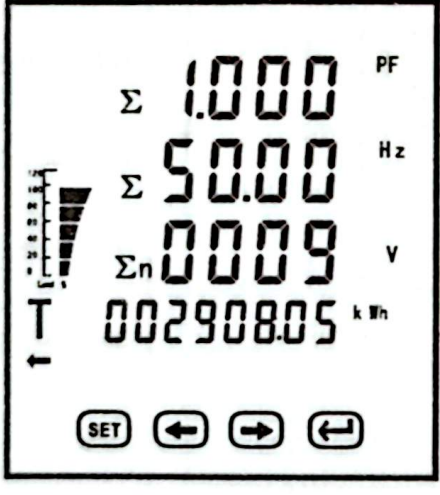
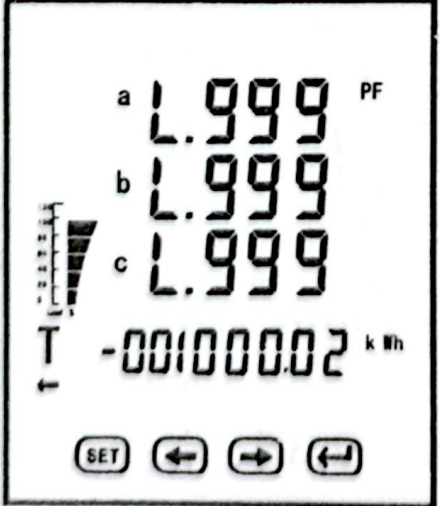
6 2 72×72,80×80,96×96 LED screen display (see Fig.9)

(1) Panel instructions

If there is no relative symbol display or the set data not working, It means the product is without the relative function.

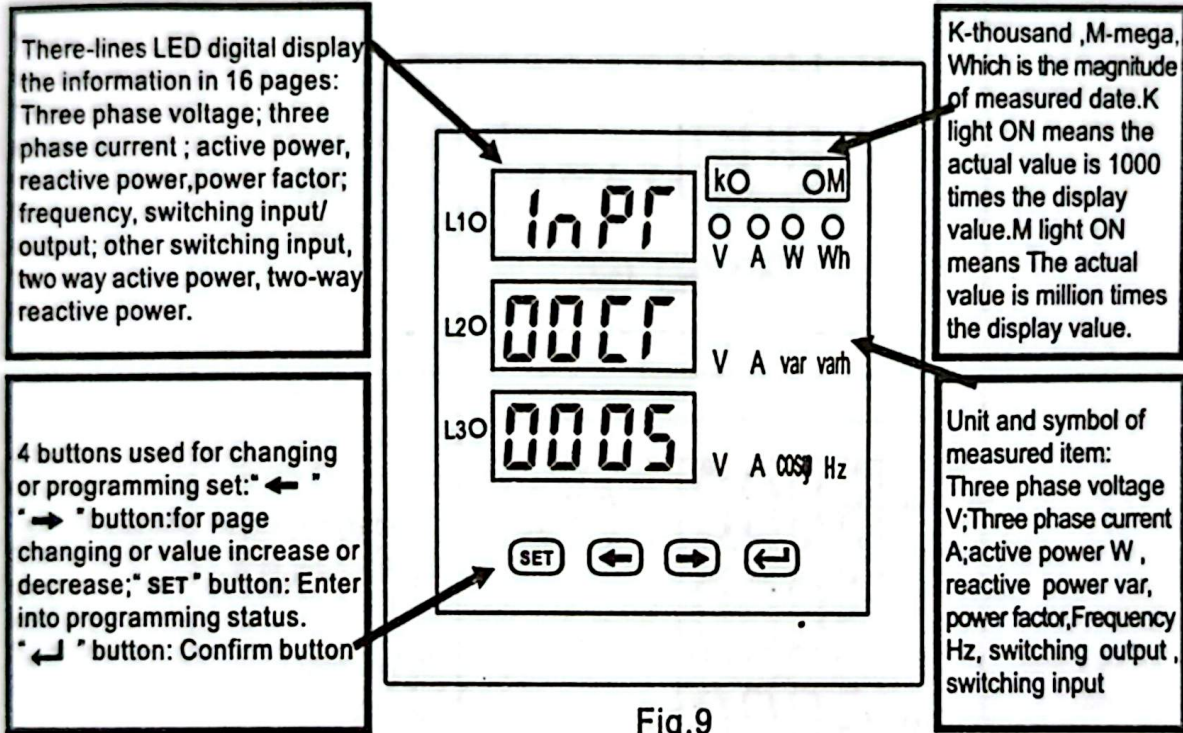

Fig.9

(2) The contents of displayed page (see Table 6)

Page	Content	Explanation
DISP=1 Three phase voltage	<p>The screenshot shows three digital displays, each showing the value 5774. To the right of the displays are labels: 'kO MO' with four downward arrows, 'V A W Wh', 'V A var varh', and 'V A cosφ Hz'. Below the displays are four buttons: SET, left arrow, right arrow, and confirm arrow.</p>	<p>Separately display the voltage Ua,Ub,Uc (3 phase 4 line)</p> <p>In left Fig Ua=5774V Ub=5774V Uc=5774V</p>

Table 6

Table 6

<p>DISP=2 Three phase voltage</p>		<p>Separately display the voltage U_{ab}, U_{bc}, U_{ca} (line voltage)</p> <p>In left Fig $U_{ab}=10\text{kV}$ $U_{bc}=10\text{kV}$ $U_{ca}=10\text{kV}$</p>
<p>DISP=3 Three phase current</p>		<p>Display 3-phase current I_a, I_b, I_c, the unit is A.</p> <p>In left Fig $I_a=5\text{A}$ $I_b=5\text{A}$ $I_c=5\text{A}$</p>
<p>DISP=4 A phase Active power Reactive power Power factor</p>		<p>Display A phase Active power P_a Reactive power Q_a Power factor PF_a</p> <p>In left Fig $P_a=86.6\text{kW}$ $Q_a=0\text{var}$ $PF_a=1.0$</p>

Table 6

<p>DISP=5 B phase Active power Reactive power Power factor</p>	 <p>The meter display for B phase shows three rows of data. The top row displays '86.60' with a 'k' multiplier and 'MO' unit, representing Active power (Pb). The middle row displays '0000' with 'V A var varh' units, representing Reactive power (Qb). The bottom row displays '1.000' with 'V A cosφ Hz' units, representing Power factor (PFb). Below the displays are four control buttons: 'SET', left arrow, right arrow, and a return key.</p>	<p>Display B phase Active power Pb Reactive power Qb Power factor PFb</p> <p>In left Fig Pb=86.6kW Qb=0var PFb=1.0</p>
<p>DISP=6 C phase Active power Reactive power Power factor</p>	 <p>The meter display for C phase shows three rows of data. The top row displays '86.60' with a 'k' multiplier and 'MO' unit, representing Active power (Pc). The middle row displays '0000' with 'V A var varh' units, representing Reactive power (Qc). The bottom row displays '1.000' with 'V A cosφ Hz' units, representing Power factor (PFc). Below the displays are four control buttons: 'SET', left arrow, right arrow, and a return key.</p>	<p>Display C phase Active power Pc Reactive power Qc Power factor PFC</p> <p>In left Fig Pc=86.6kW Qc=0var PFC=1.0</p>
<p>DISP=7 Total three phase Active power Reactive power Power factor</p>	 <p>The meter display for total three phase shows three rows of data. The top row displays '86.60' with a 'k' multiplier and 'MO' unit, representing Active power (P). The middle row displays '0000' with 'V A var varh' units, representing Reactive power (Q). The bottom row displays '1.000' with 'V A cosφ Hz' units, representing Power factor (PF). Below the displays are four control buttons: 'SET', left arrow, right arrow, and a return key.</p>	<p>Display total three phase Active power P Reactive power Q Power factor PF</p> <p>In left Fig P=86.6kW Q=0var PF=1.0</p>

Table 6

<p>DISP=8 Frequency</p>		<p>The left Fig. shows that the present frequency is 50.00HZ.</p>
<p>DISP=9 Positive active energy</p>		<p>The left Fig. shows the positive active energy value, the second line means the higher 4 digits, the third line means the lower 4 digits. It means the value of positive active energy is 356020.50 kWh.</p>
<p>DISP=10 Negative active energy</p>		<p>The left Fig. shows the negative active energy value, the second line means the higher 4 digits, the third line means the lower 4 digits. It means the value of negative active energy is 356020.50 kWh.</p>

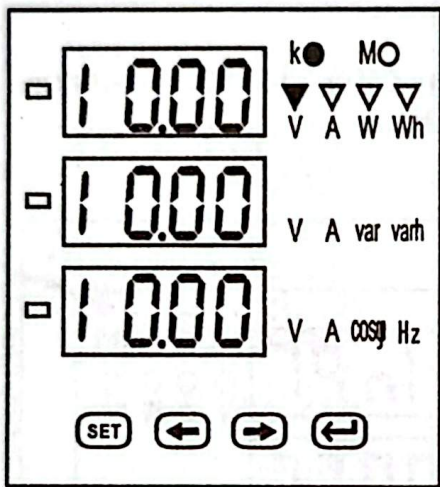
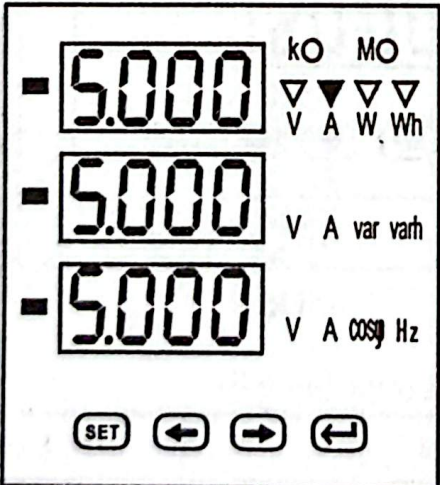
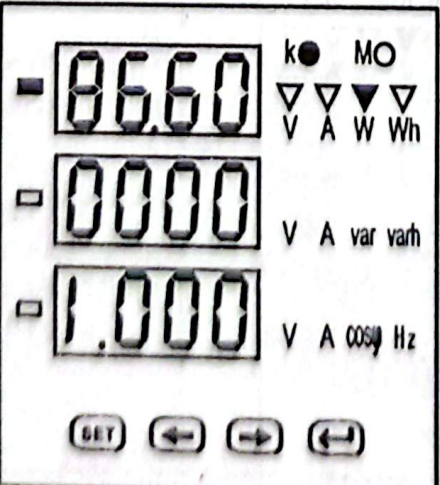
Table 6

<p>DISP=11 Positive reactive energy</p>		<p>The left Fig. shows the positive reactive energy value, the second line means the higher 4 digits, the third line means the lower 4 digits, consist by one 8 bit value. It means the value of positive reactive energy is 356020.50 kvarh.</p>
<p>DISP=12 Negative reactive energy</p>		<p>The left Fig. shows the negative reactive energy value, the second line means the higher 4 digits, the third line means the lower 4 digits, consist by one 8 bit value. It means the value of negative reactive energy is 356020.50 kvarh.</p>
<p>DISP=13 Switch output information from 1 to 4 loop</p>		<p>The data in first line is effective information; which means the 1st loop is ON, the 2nd loop is OFF.</p>

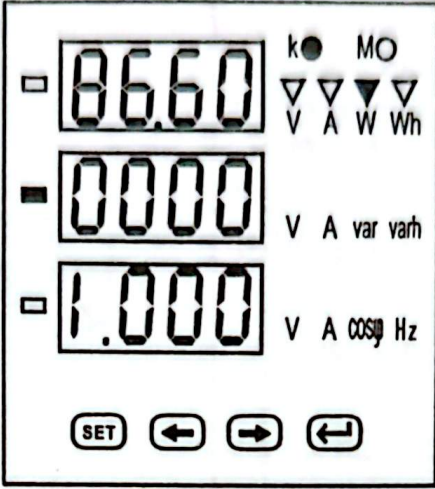
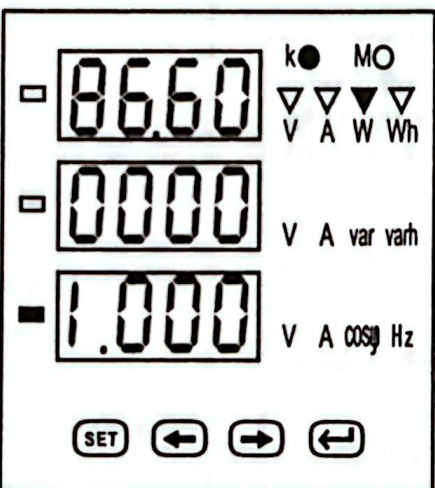
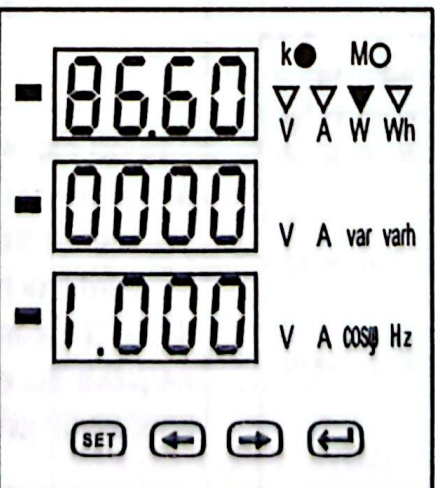
Table 6

<p>DISP=14 Switch output information from 1 to 4 loop</p>		<p>The data in second line is effective information; which means the 1st loop is ON, the 2nd loop is OFF.</p>
---	---	---

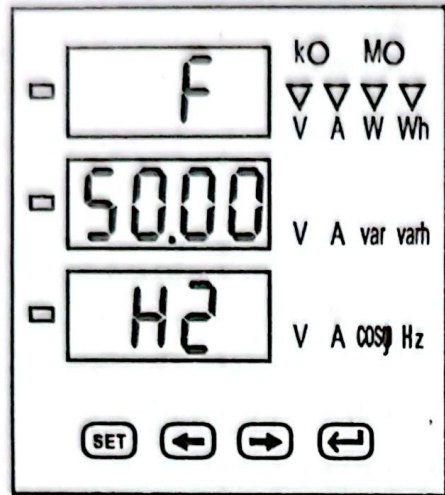
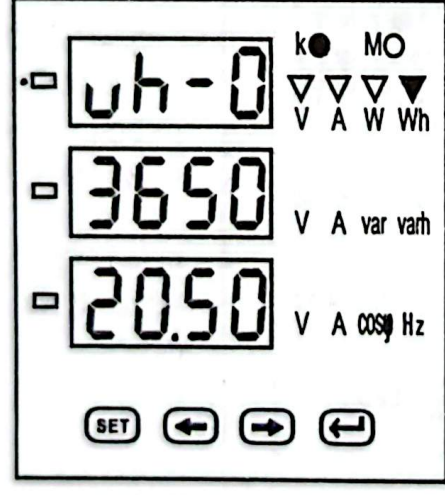
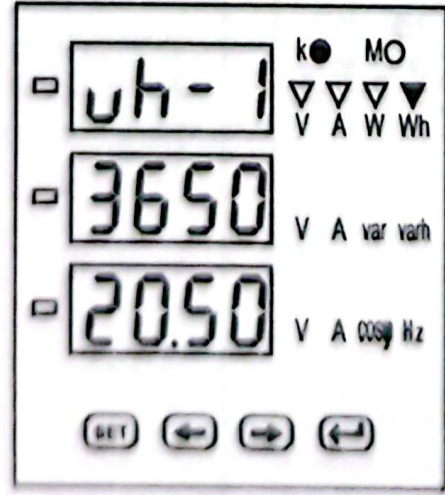
7. Communication Protocol

7.1 physical layer

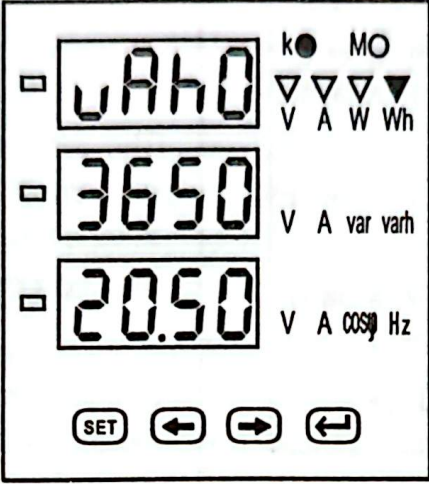
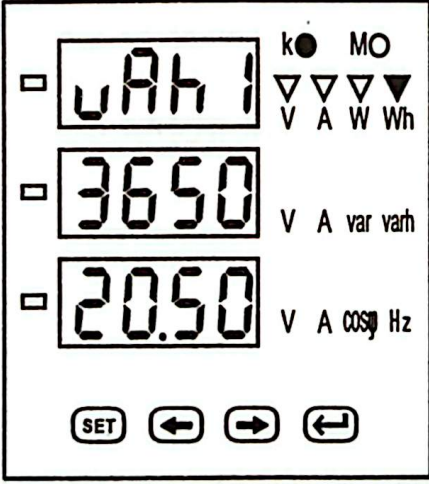
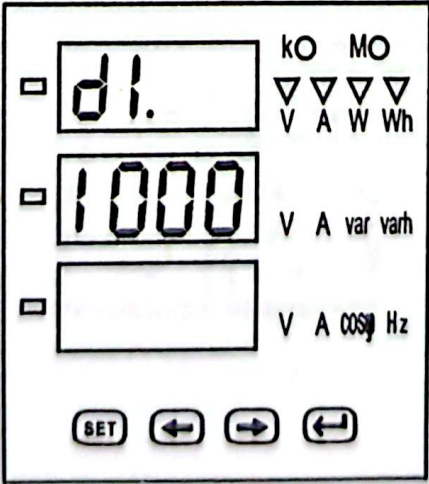
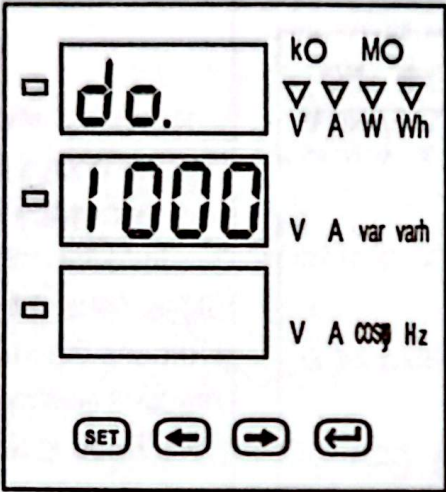
7.1.1 RS485 communication port, asynchronous half-duplex mode;

7.1.2 Communication speed 1200-38400bps can be set, factory default 9600dps;

7.1.3 Byte transfer format: 1 bit for initial bit, 8 bit for data bits, odd-even check (N81, E81, O81 can be selected), factory default N81.

7.2 Digital communication protocol

The meter is provided with serial asynchronism half-duplex RS485 communication port, adopt MODBUS-RTU protocol, various data can be transferred through communication line. One line can connect 32pcs meter at the same time, each meter can set different communication address. The communication terminal number of different series meters is different. communication should be connected by the shielded twisted-pair cable with copper network, and the diameter not less than 0.5mm^2 . When wiring, keep the communication wire away from strong electric cables or other strong electric field, T type network Wiring is recommended (see Fig.10), Star-type or other wring is not recommended.

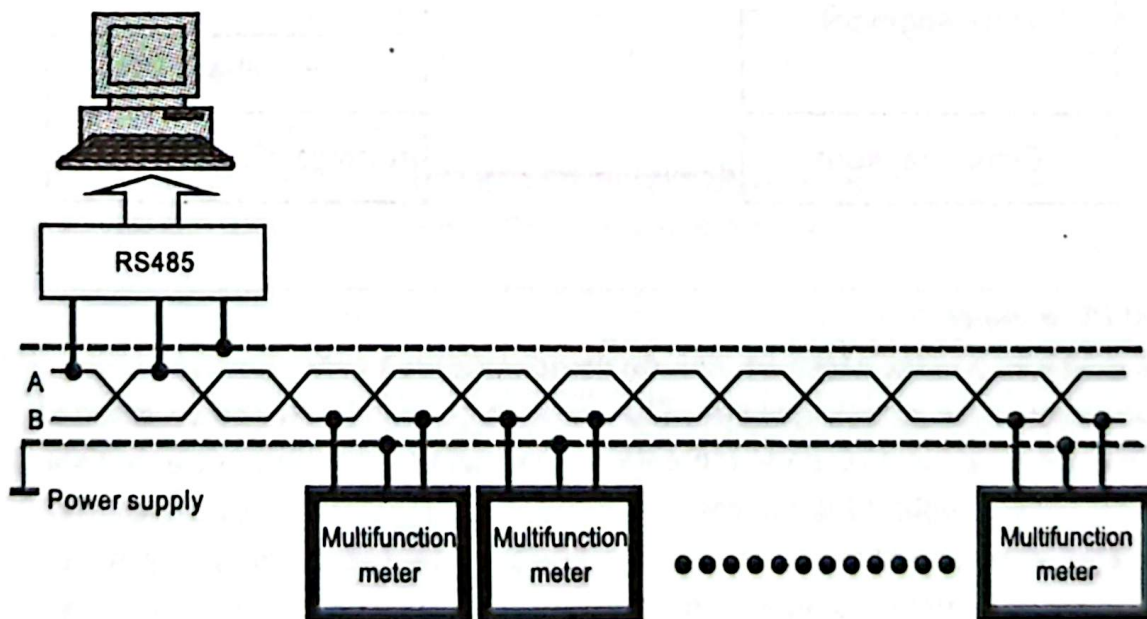
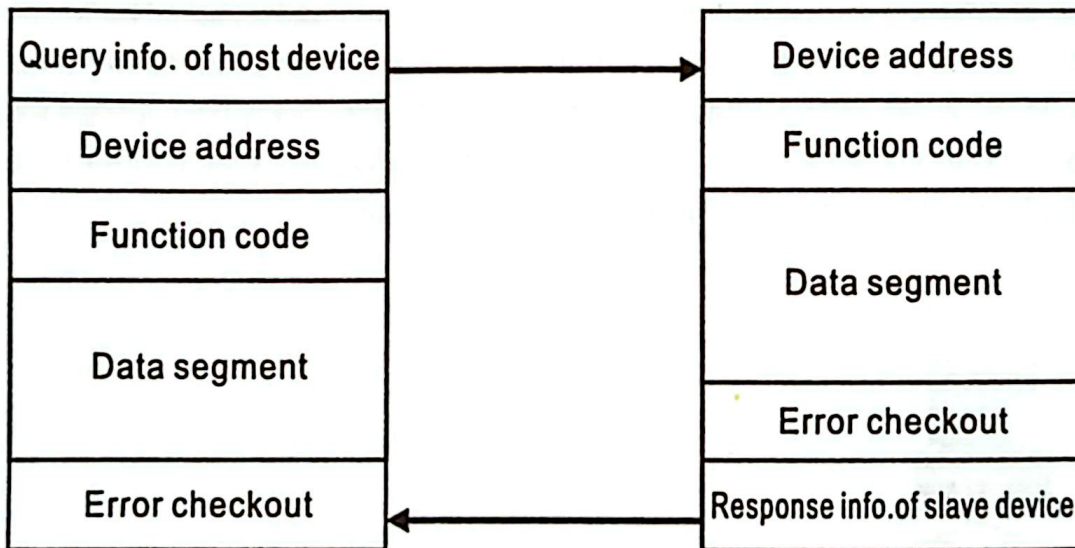

Fig.10

MODBUS-RTU communication protocol:

MODBUS protocol adopt host-slave response mode in one communication line. The signal of host computer addressing to the terminal device (Slave computer) with one address, then the terminal device send response signal back to host computer in the opposite direction. In one communication line, the communication data flow is transmitted in two opposite directions. (half-duplex working mode). MODBUS protocol only allow the communication between Host computer (PC,PLC, etc) and terminal device(see Fig.11), not allow the data exchange between terminal devices, so each terminal device will not occupy the communication lines when initialized, but only response the query signal to the host computer.

Fig.11



Host PC enquiry:

The query information frames include device address code, function code, data information code ,checkout code. The address code indicate the selected slave PC device; The function code indicate the executed function of selected slave device, for example, function code 03 or 04 means that the slave device will read the register and send back the content; The data segment include the other additional information of executed function, for example, in reading command, reading from which register? How many register to be read? The checkout code used for checking the correctness of one frame information, providing the information verification method for slave device, it adopts CRC 16 checkout rules.

Slave PC response:

If slave PC respond normally, the information include the slave address code, function code, data code and CRC 16 checkout code. Data code include the collected data from slave device, for example, register value or status. If the error occurs, the slave device will not respond. The transmission mode means one series independence data structure in one data frame and the rules for data transmission. The below defines the transmission mode compatible with MODBUS protocol RTU mode. Each bit of byte: 1 start bit, 8 data bit, (odd-even check bit), 1 stop bit (with odd-even check bit) or 1 stop bit (without odd-even check bit).

Data frame structure (Message format) see Table 7

Table 7

Address code	Function code	Data code	Checkout code
1 BYTE	1 BYTE	N BYTE	2 BYTE

Slave PC response:

If slave PC respond normally, the information include the slave address code, function code, data code and CRC 16 checkout code. Data code include the collected data from slave device, for example, register value or status. If the error occurs, the slave device will not respond. The transmission mode means one series independence data structure in one data frame and the rules for data transmission. The below defines the transmission mode compatible with MODBUS protocol RTU mode. Each bit of byte: 1 start bit, 8 data bit, (odd-even check bit), 1 stop bit (with odd-even check bit) or 1 stop bit (without odd-even check bit).

Function code: (see Table 8)

The code indicate which function should be operated by the terminal. Below Table shows the function code and their meaning and function.

Table 8

Code	Meaning	Action
01	Read switching output status	Get switching output status
02	Remote switch capacity input status	Get switching input status
03	Read the value of data register	
04	Read the value of data register	
05	Remotely control single switching output operation	
06	Write single register	Set the binary value to relative one register
0F	Remotely control more than one switching output operation	Get present binary value of one or more register
10H	Write preset register	Set the binary value to relative registers

Checkout code:

Error checkout (CRC) domain take 2 bytes, include one 16 bit binary value. CRC value is calculated by transmission device, then attached to data frame; When receiving device receive data, CRC value will be calculated again, then compare with the received value of CRC domain, if two values are not equal, the error occurs.

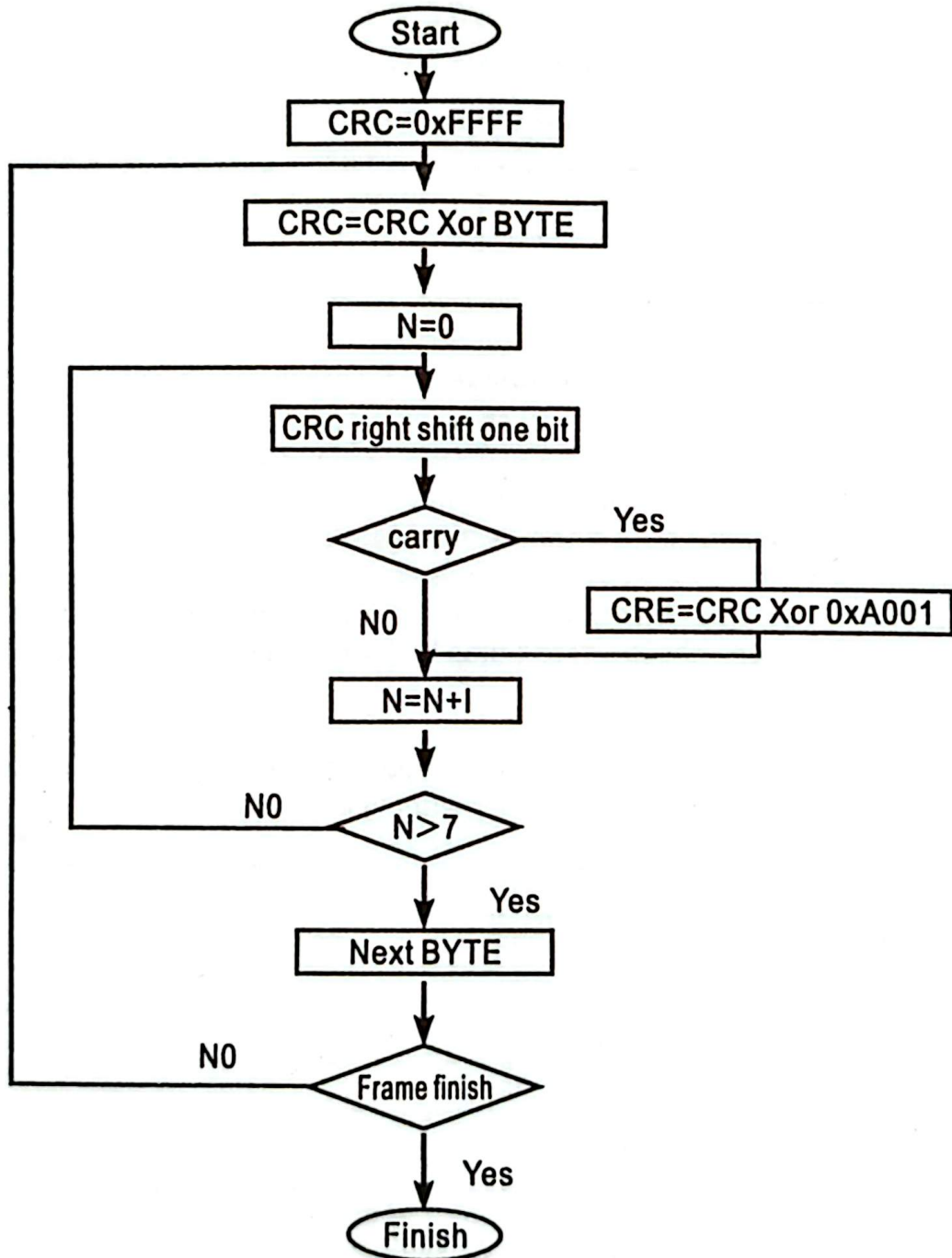

7.3 Message instruction format

Read switching output status 0 x 01 (see Table 9)

Table 9

Host PC query the command			Slave PC response	
Slave PC address	1 Byte	1 ~247	Slave PC address	1 Byte
Function code	1 Byte	0x01	Function code	1 Byte
Starting relay address	2 Bytes	0x0000(Fixed)	Byte number of register	1 Byte
Relay quantity	2 Bytes	0x0004(MAX)	Register value	N Bytes
CRC checkout code	2 Bytes		CRC checkout code	2 Bytes

Input status command of remote-check switch 0 x 02 (see Table 10)

Table 10

Host PC query the command			Slave PC response	
Slave PC address	1 Byte	1 ~247	Slave PC address	1 Byte
Function code	1 Byte	0x02	Function code	1 Byte
Starting switch address	2 Bytes	0x0000(Fixed)	Byte number of register	1 Byte
Remote-check switch quantity	2 Bytes	0x000C(MAX.)	Register value	N Bytes
CRC checkout code	2 Bytes		CRC checkout code	2 Bytes

Command of remote-control single-loop switching output 0 x 05 (see Table 11)

Table 11

Host PC query the command			Slave PC response	
Slave PC address	1 Byte	1 ~247	Slave PC address	1 Byte
Function code	1 Byte	0x05	Function code	1 Byte
Starting relay address	2 Bytes	0x0000~ 0x0003	Starting relay address	2 Bytes
Relay action value	2 Bytes	0xFF00/ 0x0000	Relay action value	2 Bytes
CRC checkout code	2 Bytes		CRC checkout code	2 Bytes

Output command of remote-check multi-loop switch 0 x 0F (see Table 12)

Table 12

Host PC query the command			Slave PC response	
Slave PC address	1 Byte	1 ~247	Slave PC address	1 Byte
Function code	1 Byte	0x0F	Function code	1 Byte
Starting relay address	2 Bytes	0x0000(Fixed)	Starting relay address	2 Bytes
Relay quantity	2 Bytes	0x0004(Fixed)	Relay quantity	2 Bytes
Byte numbers of data	1 Byte	0x01	CRC checkout code	2 Bytes
Multi-Relay action value	1 Byte			
CRC checkout code	2 Bytes			

7.4 Message examples

(1) Read remote-control/Alarm switching output status (Function code 0x01)

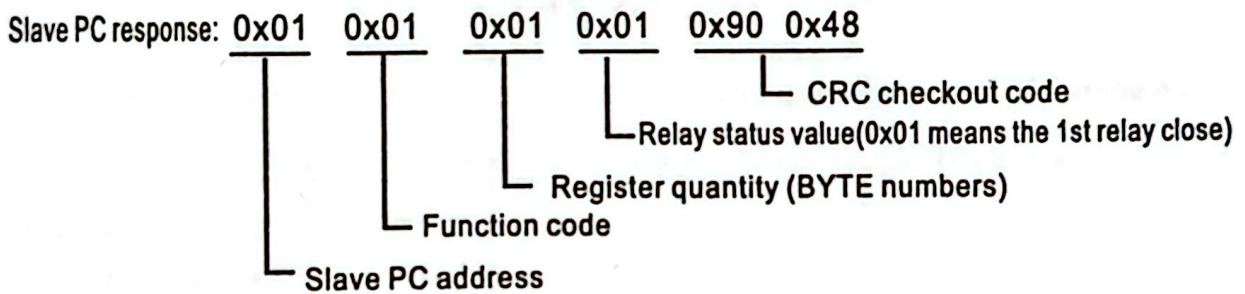
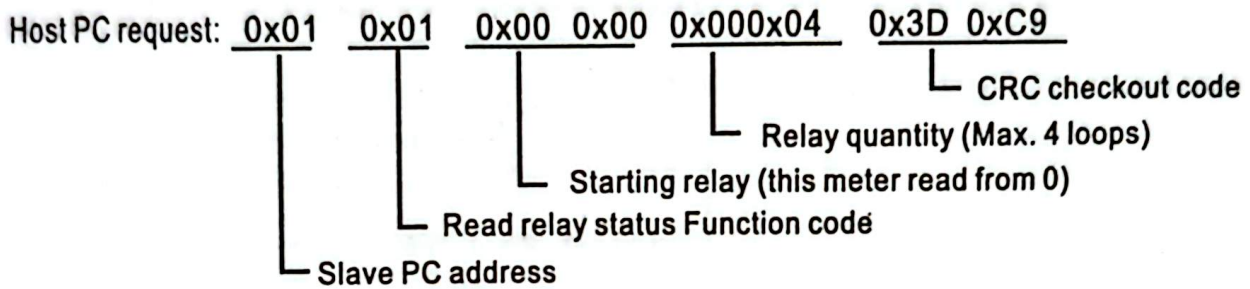

Description: The relay status value corresponds to the status value of each switch output starting from the lowest bit of each byte according to the MODBUS protocol. 1 means the ON status and 0 means the OFF status. Binary "0000 0011" of "0x03" Indicates that the first and second relays are closed.

(2) Remote-check switching input status (Function code 0x02)

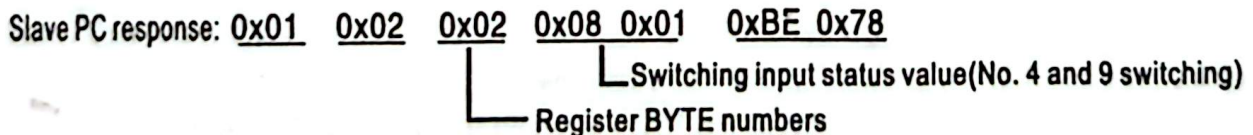
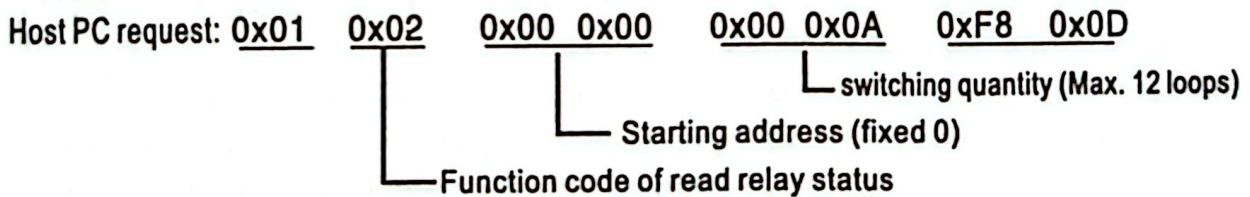

Description: The switching input status value corresponds to the status value of each switching input starting from the lowest bit of each byte according to the MODBUS protocol. 1 means the ON status and 0 means the OFF status.

(3) Remote-control single switching output status (Function code 0 x 05)

NOTE: This meter has a maximum of 4 switching output. The use of remote control commands must require the relay to work in remote control mode.

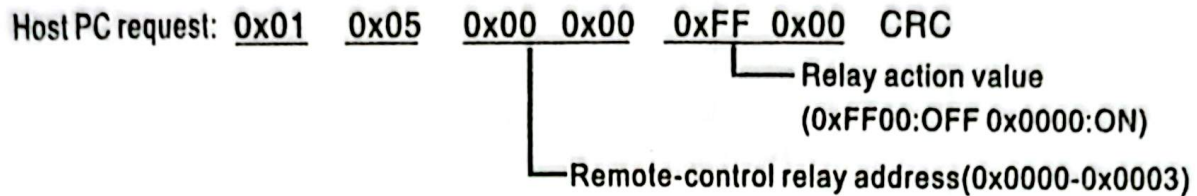

Slave PC response: 0x01 0x05 0x00 0x00 0xFF 0x00 CRC

(4) Remote-control multi-loop switching output status (Function code 0 X 0F)

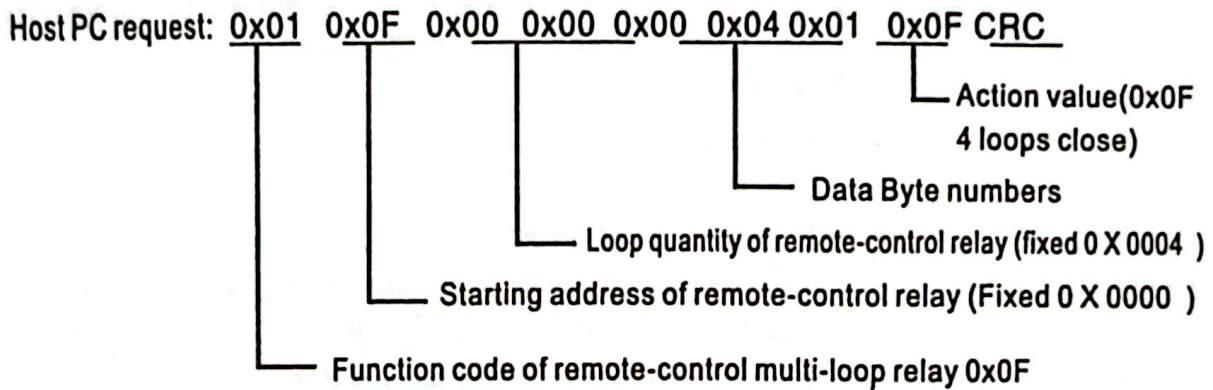

Slave PC response: 0x01 0x0F 0x00 0x00 0x04 CRC

The communication protocol of this meter follows the standard MODBUS-RTU protocol. And in the communication address Table, there are both floating-point primary power grid data and secondary power grid fixed-point integers. Customers can choose to read the corresponding data according to their own system requirements. MODBUS protocol communication address information table is shown in Table 17.

Communication message examples:

Read data(function code:03): this function makes the user get the data collected and recorded by terminal device and The system parameter. There is no quantity limit when the host PC collect the data in one time, but can't exceed the range of defined address. The below example is from terminal device addressing 12(0CH), read 3 data Ia, Ib, Ic (each address take 2 byte, the beginning address of Ia is 43 (2BH) , data length is 3(03H)byte.

Query the data frame (Host PC) (See Table 13)

Table 13

Address	Command	The beginning register address (high)	The beginning register address (low)	Register quantity (high)	Register quantity (low)	CRC16 (low)	CRC16 (High)
01H	03H	00H	58H	00H	02H	45H	D8H

Response data frame (slave PC) (see Table 14)

It means Ia=0000C317H(4.9943).

Table 14

Address	Command	Data length	Data 1234	CRC16 (low)	CRC16 (High)
01H	03H	04H	00H 00H C3H 17H	72H	E5H

Preset data (function code: 16): this function allows to change the contents of multiple registers (electrical measurement can be written with this function number, it should be emphasized that the written data is a writable attribute parameter, the number does not exceed the address Range), the following example is a communication method with a current transformation ratio of $400 / 5A = 80$.

Query the data frame (Host PC) (See Table 15)

Table 15

Address	Command	The beginning register address (high)	The beginning register address (low)	Register quantity (high)	Register quantity (low)	Number of characters	Written data	CRC16 (low)	CRC16 (High)
01	10	00	2E	00	01	02	0050	A0	22

Query the data frame (Slave PC), indicates that the data has been written (See Table 16)

Table 16

Address	Command	The beginning register address (high)	The beginning register address (low)	Register quantity (high)	Register quantity (low)	CRC16 (low)	CRC16 (High)
01	10	00	2E	00	01	61	C0

Three Phase Multifunction Network Power Meter

MODBUS Address Data Table (see Table 17)

Table 17

Address	Description	Data format	Data length	Read/write	Explanation
0001					
0002	Corresponding item of output 1	uchar	1	R/W	Corresponding item of switching output
	Level delay of output 1	uchar	1	R/W	Unit: Second
0003	Corresponding value of output 1	uint	2	R/W	Alarm value
0004	Return difference value of output 1	uint	2	R/W	Returned value
0005	Limit alarm of output 1	uint	2	R/W	Min. value of lower alarm
0006-0019	Output 2-6 loops				
001A	Corresponding item of analog output 1	uchar	1	R/W	Corresponding item of analog output
	Corresponding mode of analog output 1	uchar	1	R/W	0,4-20mA 1,0-20mA
001B	Corresponding value of analog output 1	uint	2	R/W	Analog corresponding value
001C-0021	2-4 loops of analog output				
0022-0027	Backup				
0028	Power display setting	uchar	1	R/W	Reserve
	Wiring mode selection	uchar	1	R/W	see the address explanation
0029	Power-on display	uchar	1	R/W	displayed contents
	Back-light delay time	uchar	1	R/W	Back-light delay time
002A	Luminance	uchar	1	R/W	LED Luminance
	CT quantity	uchar	1	R/W	0,3CT 1,2CT
002B	Time setting of scrolling display				
002C	Voltage multiplying power	uint	2	R/W	1-9999
002D	PT divisor	uint	2		1-9999
002E	Current multiplying	uint	2	R/W	1-9999
002F	Backup				
0030	Voltage null	uint	2	R/W	0.001-9.999
0031	Current null	uint	2	R/W	0.001-.500
0032	Power null	uint	2	R/W	0.001-9.999
0033	Communication protocol	uint	2	R/W	0-RS485Modbus
0034	Communication address	uint	2	R/W	0-247
0035	Baud rate	uint	2	R/W	1-6,1:1200,2:2400, 3:4800,4:9600(default), 5:19200,6:38400

Three Phase Multifunction Network Power Meter

0036		checking	uint	2	R/W	0-2,0:even checking, 1:odd checking, 2:no checking(default)
0037		Backup				
0038-003B		645 communication address	uchar	8	R/W	BCD code
003C		Baud rate of No.2 loop	uint	2	R/W	1-6,1:1200,2:2400, 3:4800,4:9600(default), 5:19200,6:38400
003D		No.2 loop checking	uint	2	R/W	0-2,0:even checking, 1:odd checking, 2:no checking(default)
003E-003F		Backup				
0040		Switching output information	uint	2	R	High 8 bit backup, low 8 bit valid 0: OFF 1: ON
0041		Switching input information	uint	2	R	0: OFF 1: ON
0042		A phase voltage	ulong	4	R	4 decimal point (0.0001V)
0043						
0044		B phase voltage	ulong	4	R	4 decimal point (0.0001V)
0045						
0046		C phase voltage	ulong	4	R	4 decimal point (0.0001V)
0047						
0048		Average phase voltage	ulong	4	R	4 decimal point (0.0001V)
0049						
004A		Phase voltage unbalance	ulong	4	R	0.01-99.99 2 decimal point (%)
004B						
004C		AB line voltage	ulong	4	R	4 decimal point (0.0001V)
004D						
004E		BC line voltage	ulong	4	R	4 decimal point (0.0001V)
004F						
0050		CA line voltage	ulong	4	R	4 decimal point (0.0001V)
0051						
0052		Average line voltage	ulong	4	R	4 decimal point (0.0001V)
0053						
0054		Zero-sequence voltage	ulong	4	R	4 decimal point (0.0001V)
0055						

Three Phase Multifunction Network Power Meter

0056	Line voltage unbalance	ulong	4	R	0.01-99.99 2 decimal point (%)
0057					
0058	A phase current	ulong	4	R	4 decimal point (0.0001A)
0059					
005A	B phase current	ulong	4	R	4 decimal point (0.0001A)
005B					
005C	C phase current	ulong	4	R	4 decimal point (0.0001A)
005D					
005E	Average current	ulong	4	R	4 decimal point (0.0001A)
005F					
0060	Zero-sequence current	ulong	4	R	4 decimal point (0.0001A)
0061					
0062	Current unbalance	ulong	4	R	0.01-99.99 2 decimal point (%)
0063					
0064	A phase active power	long	4	R	4 decimal point (0.0001kW)
0065					
0066	B phase active power	long	4	R	4 decimal point (0.0001kW)
0067					
0068	C phase active power	long	4	R	4 decimal point (0.0001kW)
0069					
006A	Total active power	long	4	R	4 decimal point (0.0001kW)
006B					
006C	A phase reactive power	long	4	R	4 decimal point (0.0001kvar)
006D					
006E	B phase reactive power	long	4	R	4 decimal point (0.0001kvar)
006F					
0070	C phase reactive power	long	4	R	4 decimal point (0.0001kvar)
0071					
0072	Total reactive power	long	4	R	4 decimal point (0.0001kvar)
0073					
0074	A phase apparent power	long	4	R	4 decimal point (0.0001kVA)
0075					

Three Phase Multifunction Network Power Meter

0076		B phase apparent power	long	4	R	4 decimal point (0.0001kVA)
0077						
0078		B phase apparent power	long	4	R	4 decimal point (0.0001kVA)
0079						
007A		Total apparent power	long	4	R	4 decimal point (0.0001kVA)
007B						
007C		A phase power factor	int	2	R	3 decimal point
007D		B phase power factor	int	2	R	3 decimal point
007E		C phase power factor	int	2	R	3 decimal point
007F		Total power factor	int	2	R	3 decimal point
0080		Frequency	uint	2	R	Frequency 2 decimal point
0081		Backup				.
0082		Total positive active energy	ulong	3	R	Secondary side (0.001kWH)
0083						
0084		Total negative active energy	ulong	3	R	Secondary side (0.001kWH)
0085						
0086		Total positive reactive energy	ulong	3	R	Secondary side (0.001kvarH)
0087						
0088		Total negative reactive energy	ulong	3	R	Secondary side (0.001kvarH)
0089						
008A		Total positive active energy	float		R	Primary side
008B						
008C		Total negative active energy	float		R	Primary side
008D						
008E		Total positive reactive energy	float		R	Primary side
008F						
0090		Total negative reactive energy	float		R	Primary side
0091						