

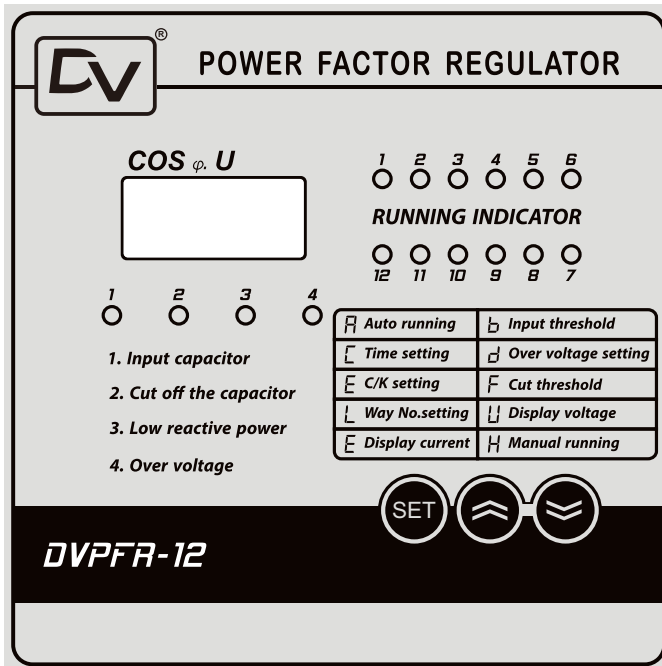

QUALITY
YOU CAN
TRUST

DVPFR-12

POWER FACTOR REGULATOR



Brief Introduction

DVPFR-12 Power Factor Regulator adopts the most advanced SCM control technology at home and abroad, having memory function to modified parameters. It has characteristics of high precision, high sensitivity, strong anti-interference capacity by analog type controller, and with non-shutdown. This series product conforms to JB/t9663-1999 standard, can be widely used in different electric network conditions.

Working Condition

- Power voltage : Rated value is AC 220V/ 380V, fluctuation should not exceed $\pm 10\%$.
- Ambient temperature : $-25^{\circ}\text{C}\sim 55^{\circ}\text{C}$
- Relative humidity : Max 90%(at 20C)
- Altitude : not exceed 2000m
- Environmental condition : without explosive and flammable dangerous medium, without corrosive metal gas and the conductive dust that may damage the electric insulation

Technical Parameter

I Basic technical parameters

- Rated current : AC 0-5A
- Frequency : 50HZ/60HZ
- Protection grade of shell : IP40
- Current input impedance : $<0.02\ \Omega$
- Rated voltage : AC 220V/380V
- Power : Max 8W
- Sensitivity : 100mA
- Contact capacity : Dynamic state DC12V/50mA, Static state AC 220V/7A

II. Adjustable range for control parameters and ex-work setting value





Technical Parameter	Parameter Value	Ex-Work Setting Value
Over Voltage Preset	230~300V/400~500V Adj Step Length 1V	245V/430V
Delay Preset	1~250s Adjustable Step Length 1V	30s
C/K Ratio	0.01~1.00 Adjustable Step Length 0.01	0.10
Input Threshold	0.08~0.99 Adjustable Step Length 0.01	0.95
Resect Threshold	Ind 0.91~cap~.90 Adj Step Length 0.01	1.00
Control Group No	1~12/1~16 step can be set	Max value for hardware

Operation instruction



Function selection

The first position of digit tube (LED) displays function code. According to code table if press  for less than 0.5s under automatic state it will directly enter into manual state, if exceed 1S, all function codes can be chosen circularly. (Refer to code table)







Parameter modification

If you choose a function code, release  key, press  key and the parameter will increase. Press  key, the parameter will decrease. After modified, release the pressed key, operate  key within 30S it will transfer to automatic state. Now the new parameter will be saved automatically.

Manual running

Under automatic state,  click can directly enter into manual running state. The first position of Led displays "H", press  Key it will input; press  Key will cut Code table

Code table

Code	Code meaning	Digit displayed contents	Operate  or 	Remarks
<i>A</i>	Auto running	Power factor of electric network	Void	1.It is valid by pressing the button for over 0.5s when operating  ,  , and  keys. 2.When the codes under b~l these six states, if there is no key-pressing operation within 30S, it will automatically return to auto running state. 3.When the codes under U, P, H these three states, transfer to auto running state just can be realized through operating  key.
<i>b</i>	Input threshold	Input point of power factor	0.80~0.99 For option	
<i>ℓ</i>	Time setting	Setting value of delay time	1~250s For option	
<i>d</i>	Over voltage setting	Setting value of over voltage	230~300V/400~500V For option	
<i>E</i>	C/K setting	Transformation ratio of current divide capacitance	0.01~1.00 For option	
<i>F</i>	Cut threshold	Resect point of power factor	0.91~.90 For option	
<i>ℓ</i>	Way No. setting	Setting value of output loop No.	1-12 step for option	Under R, U, P these three states, controller will automatically control the input action of capacitor, there will be corresponding indication on the panel.
<i>U</i>	Display voltage	Sampling voltage value (V)	Void	
<i>P</i>	Display current	Sampling current value (A)	Void	
<i>H</i>	Manual running	Power factor of electric network	Capacitor groups will input or cut in turn.	

C/K setting instruction

C/K value is the reactive threshold value of input-cut capacitor. Each step of capacitor power(kvar)is divided by the ratio k(the ratio of current sampling current transformer), if for unequal capacitance compensation cabinet, according to the min capacitaor to calculate for each step of capacitor. If it is set to 0.00, the controller will not consider the size of reactive power according the input-cut of power factor But user should pay attention that if the set value is undersize, which may cause input-cut vibration as over size capacitor. If oversize set, which may cause the controller judge low reactive and can't input capacitor for compensation because of inadequate reactivepower. So through calculation to reasonably set C/K is very important To set C/K according to different capacitor and ratio of current transformer, refer to the following table

Transformer ratio (k)	Capacitor power of each step (kvar)														
	3	4	5	6	7.5	8	10	12	15	18	20	30	40	50	60
25/5	0.60	0.80	1.00												
50/5	0.30	0.40	0.50	0.60	0.75	0.80	1.00								
75/5	0.20	0.27	0.33	0.40	0.50	0.53	0.67	0.80	1.00						
100/5	0.15	0.20	0.25	0.30	0.38	0.40	0.50	0.60	0.75	0.90	1.00				
150/5	0.10	0.13	0.17	0.20	0.25	0.27	0.33	0.40	0.50	0.60	0.67	1.00			
200/5	0.08	0.10	0.13	0.15	0.19	0.20	0.25	0.30	0.38	0.45	0.50	0.75	1.00		
300/5	0.05	0.07	0.08	0.10	0.12	0.13	0.17	0.20	0.25	0.30	0.33	0.50	0.67	0.83	1.00
400/5	0.04	0.05	0.07	0.08	0.09	0.10	0.13	0.15	0.19	0.23	0.25	0.38	0.50	0.63	0.75
500/5	0.03	0.04	0.05	0.06	0.07	0.08	0.10	0.12	0.15	0.18	0.20	0.30	0.40	0.50	0.60
600/5	0.02	0.03	0.03	0.05	0.06	0.07	0.08	0.10	0.13	0.15	0.17	0.25	0.33	0.42	0.50
800/5	0.02	0.03	0.04	0.04	0.05	0.05	0.07	0.08	0.09	0.11	0.13	0.19	0.25	0.31	0.38
1000/5	0.01	0.02	0.03	0.03	0.04	0.04	0.05	0.06	0.08	0.09	0.10	0.15	0.20	0.25	0.30
1250/5	0.01	0.01	0.02	0.02	0.03	0.03	0.04	0.05	0.06	0.07	0.13	0.19	0.25	0.31	0.38
1500/5	0.01	0.01	0.02	0.02	0.03	0.03	0.03	0.04	0.05	0.06	0.08	0.10	0.13	0.17	0.20
2000/5		0.01	0.01	0.01	0.02	0.02	0.02	0.03	0.03	0.04	0.05	0.07	0.10	0.12	0.15
2500/5			0.01	0.01	0.01	0.02	0.02	0.02	0.03	0.03	0.04	0.06	0.08	0.10	0.12
3000/5				0.01	0.01	0.01	0.01	0.02	0.02	0.03	0.03	0.05	0.07	0.08	0.10
4000/5					0.01	0.01	0.01	0.01	0.02	0.02	0.02	0.04	0.05	0.06	0.07

Connecting diagram

Power Supply : 380V
Tapping size : 113x113mm

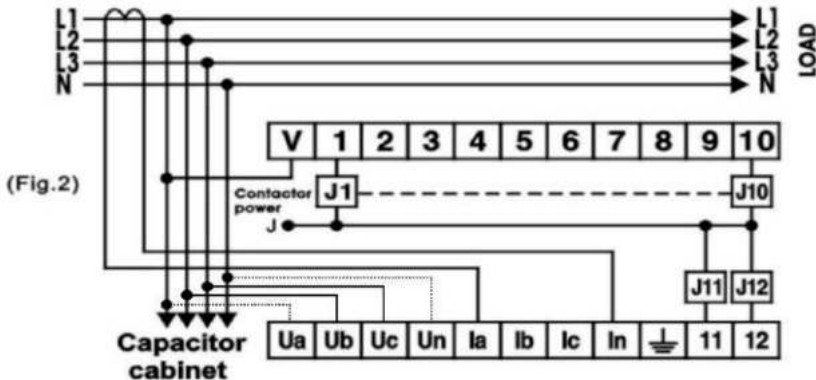

Wiring :

1. Ub, Uc voltage signal input terminals at L2 and L3 phase
2. Ia, In current signal input terminals at L1 phase CT
3. V common terminal of control output terminal.
4. 1-12 is 12 steps output terminal
5. If contactor is 380V, connect P to L2 or L3.
6. If contactor is 220V, connect P to N phase.

Notice for inspection

1. Connect power and sampling current according to the connection diagram Led will display 0168(wish you make a fortune all the way) after delay for 0.5s, it displays power factor.
2. When the voltage exceeds the over voltage setting value, the over voltage indicator light shines, LED alternately displays the electric network voltage value and power factor, and cutt one step capacitor per 5s.
3. When there is no sampling current or the current is less than 100mA,LED only displays 000. Controller doesn't detect the power factor, at the same time it executes cut action.
4. Under the conditions of non-over voltage, on- under current and auto running state, if electric network power factor ind. input threshold and the reactive power exceeds C/K setting value, the input indicator light shines, after continuously exceeding the delay time, it input one step. If electric network power factor cap. reset threshold, the reset indicator light shines, after continuously exceeding the delay time, it cut one step; If power factor exceeds input threshold and less than cut threshold, it will not input and cut.
5. When the low reactive indicator light shines, which shows the current power factor is less than input threshold setting value, but the reactive power of electric network is less than the capacitor value of each step, as this time it will not input capacitor to avoid over compensation.

Notice for operation

1. Input threshold and cut threshold of controller all can be set. For the electric network with big load changing frequency(Such spot welder, elevator etc). and unstable power factor, please notice that set the cut threshold a certain value higher than input threshold, at the same adjust the delay time longer properly to avoid the over frequent input-cut, which may affect the service life of the product.
2. Big difference between displayed power factor and theoretical predicted value(Such below 0.3 or it displays ind. just after starting) or the power factor changes abnormally along with the input of capacitor, which are caused by wrong connection for sampling signal phases. The simple solving methods is to exchange another phase voltage with one phase in sampling voltage, there is only one correct method in 3 kinds of phase connections.(Note:It is invalid to interchange sampling voltage or two lines of current.)
3. Almost no change for power factor along with the input of compensation capacitance. Check the sampling current transformer whether it is set to the busbar of general cabinet of distribution box, otherwise there is no way to correctly measure the power factor after compensation.
4. Input indicator light on operation panel of controller has shone but no action for contactor, check whether there is voltage between the input terminal of control trunk of contactor aside the sampling voltage terminal of controller and common power trunk of contactor groups, or the voltage matches the rate voltage of controller or not.
5. Secondary side of sampling current transformer should not be lpt connected other devices and meters in parallel. If has, change it to serial connection. Otherwise the controller will display A 000 because of inadequate sampling current, or cause the signal phase deflection that may shows the wrong power factor value.