

Multifuntion Network Electric Power Meter

Instruction Book

User Manual v1.0

Thank you to choose our product Multifuntion monitor meter, please read this instruction book carefully as below point :

CAUTION

- ◆ This device must be installation and maintain by professional;
- ◆ Before to do this device inside or outside operation,must cut input signal and power source;
- ◆ To always use fit voltage detect device to confirm meter each parts without voltage;
- ◆ Supply this device`s electric parameter must in rated range;

Undermentioned condition will result to device damager or device work in abnormal;

- ◆ Auxillary power source voltage over range
- ◆ Distribute system frequence over range
- ◆ Current,voltage input poles incorrect
- ◆ With electric pull out communication plug
- ◆ No according requirement to connect terminal



Please don't touch the terminals
when the meter is in operation!

Catalog

I . Product brief	1
1. 1 standard	1
1. 2 General	1
2. Function introduce	2
3. Technical parameter	2
4. Installation and connection	4
4. 1 Meter dimension	4
4.2 Installation sketch	5
4.3 Connection Terminal function	5
4.4 wiring	6
5. programme operation	9
6. Panel explain and measure information display	13
6.1 96 x 96、120x 120 LCD display	13
6.2 80 x 80 LCD	18
6.3 48 x 48、80 x 80、96x96、120x120 LED special display	25
7. Communication protocol	31
8. Function output	38
8. 1 Energy meter and pulse output	38
8.2 switch capacity and transimssion mould	38
9.ordinary problem and solution	42

I . Product brief

1. 1 Standard

Reference standard

GB/T 17883-1999 0.2S class and 0.5S stillness type AC active electric meter

GB/T 17882-1999 2 class and 3 stillness type AC reactive electric meter

DL/T 614-1997 multifunction electric power meter

GB/T13850-1998 AC energy transfer as analog quantity or digital signal's electric measure transmitted.

Perform Standard:

GB/T 22264.1-2008 install type digital display electric measure meter No.1 part:

Define and General Requirement.

GB/T 22264.2-2008 install type digital display electric measure meter No.2 part:

Current meter and voltage meter's special requirement

GB/T 22264.3-2008 install type digital display electric measure meter No.3 part:

Power meter and reactive power meter's special requirement

GB/T 22264.4-2008 install type digital display electric measure meter No.4 part:

frequency meter's special requirement

GB/T 22264.5-2008 install type digital display electric measure meter No.5 part:

phase meter and power factor meter's special requirement

GB/T 22264.7-2008 install type digital display electric measure meter No.7 part:

Define and General requirement

GB/T 22264.8-2008 install type digital display electric measure meter No.8 part:

commend test way

1. 2 General

Multifunction monitor meter

Multifunction monitor meter with high ability and precision power parameter, in real time measure, harmonic measure, positive and negative active power/reactive power electric energy measure, Time-sharing count, fix time mark, power quality analyse, real time wave display, event record, demand and so on function, and with configure abundance input output ports to monitor and control locale device status, and integration RS-485 communication port, integration with each kinds intelligent distribute system and power energy manage system, share abundance monitor data and power quality data.

Multifunction with best competitive, can direct instead of general power transmitted, measure meter, power energy measure meter and relative auxiliary unit, have widely application, like energy manage system, power monitor system, industry and mining enterprise, public place, intelligent building and switch board those power net system.

II. Function introduce(see the table.1)

table.1

Measure function		Remark
Real time measure	Three phase voltage	Basic function
	Three phase current	
Power, Frequency, power factor		
Electric energy measure	Active power	explain function
	Reactive power	
	Two way measure	
demand	UIPQ	explain function
Power pulse	dry contact point	
Transmitted output	4-20mA/0-5V	
Switch input	dry contact point	
Relay output	AC250V5A remote/alarm	
Leakage current detection	Zerosequencecurrent	
Communication	RS485 Port	
	MODBUS-RTU	
Display type		Special display board, LCD display

III. Technical parameter(see table .2)

table .2

		parameter	
Signal input	Connection	Three phase four wires/three phase three wires	
	Voltage	Measurement range	380V/100V
		Over load	continuous:1.2 multiple instantaneous:2 multiple
		Power consumption	< 1VA
	Current	Measurement range	5A/1A
		Over load	continuous:1.2 multiple instantaneous:2 multiple
		Power consumption	< 1VA
	Frequency	45~65Hz	

Power source	AC/DC 85~265 V <5VA
Energy pulse	Dry power optocoupler collector output fixed pulse width recording 80mS ± 20%
Communication	RS485 communication port, physical layer isolation. According international standard MODBUS-RTU agreement Communication speed 1200-9600 Test type MS1, ES1, OS1
Analog output	0/4~20mA or 0~5/10V Transmitted output Programme set transmitted Iten and relative value
relay output	Programme remote/ alarm relay output Capacity 5A/250VAC 5A/30VDC Programme alarm energy, switch input, analog input or remote way
Remote Switch	Remote switch input measure, dry contact input Program relate alarm output
Measure class	Energy: 0.5S; requence: ± 0.1Hz Active Power: 0.5S Reactive Power: 1S
Display	Special display, LCD display
Environment	Working temperature: -10~55℃ Save temperature: -20~75℃ Relative Humidity: < 80%RH
Safe	Isolation: Signal, power source, output terminal crust resistance > 5M Ω Withstand: Signal input, power source, between output crust resistance > AC2KV

IV. Installation and connection

4.1 Meter dimension(see table .3)

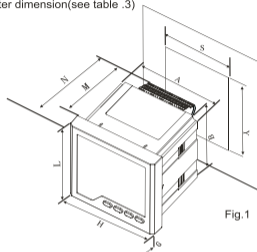

Fig.1

Installation dimension $A \times B$
 open dimension: $S \times Y$
 Panel dimension: $L \times H$ (unit mm)

Table 3

Outline dimension (L×H) Unit (mm)	Board assemble dimension (A×B) Unit (mm)	Open dimension (S×Y) Unit (mm)	Total length (N) (mm)	Depth (M) (mm)
120×120	110×110	111×111	93	78
96×96	91×91	92×92	93	78
80×80	75×75	76×76	93	78
80×80	67×67	68×68	93	78
48×48	44×44	45×45	90	84

4.2 Installation sketch(see fig.2)

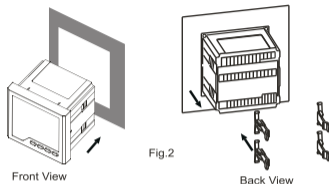

Fig.2

4.3 Connection Terminal function(see Table.4)

Table.4

Power Source	1, 2	AC/DC85-265V, AC220V
Current signal	4, 5, 6, 7, 8, 9	4,6,8 is three phase current input terminal
Voltage signal	11, 12, 13, 14	Separate is three phase voltage input UA, UB, UC, UN
Relay output	15-22	4 ways relay output
Transmitted output	30-34	4 way 4-20mA transmitted output,30 public terminal
Energy Pulse	47, 48, 49, 50	47,49 is dry power output positive port,connect exterior power source positive port
No.2 way	55, 56	Separate isA+, B-
No.1 way	58, 59	Separate isA+, B-

Use explain:

- (a) 1,2 is meter auxiliary power source in work, please ensure supply power source use in this series product, to avoiding damage product.
- (b) 4,6,8 is current transformer's input terminal, with *code mean is current's input terminal.
- (c) three phase three wires connection: in three phase three wires network, Current of B phase no need connection, UB connect to NO.14 terminal, the detail connection as per 4.4 wiring.
- (d) Detail connection port use, please according detail product crust's diagram to connection.

4.4 wiring

4.4 .1 Below introduce three kinds basic function of low voltage network diagram

1) Basic energy measure + switch capacity input+analog transmitted output(see fig.3)

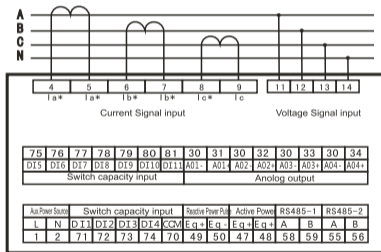

Fig.3

2) Basic energy measure + switch capacity input+switch capacity output(see fig.4)

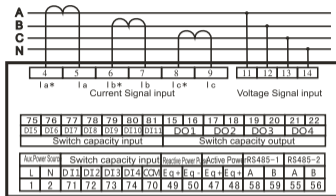

Fig.4

4.4 .2 Input Signal Wiring(See fig.6)

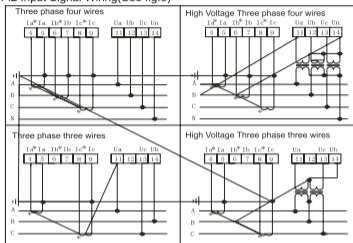

Fig.6

4.4 .2 Input Signal Wiring(See fig.6)

Connection wiring explain:

- (a)Voltage input:Input voltage no over product's rated voltage(100V or 400V),or else should consider use PT,To easy in maintain,suggest use the terminal block.
- (b)Current input:Standard rated input current is 5A,over 5A's condition should use external CT.If use other meter on the CT,connection should adopt serial type,before moving product current input wiring,must first cut CT first loop or short connect second loop,to easy in maintain,suggest use the terminal block.
- (c)Meter can work in three phase four wires or three phase three wires type,user should according present use condition choose relative connection.As usual,in no center line status,use three phase three wires type,in have center line status,use three phase four wires type.Three phase three wires can install 2 pcs CT(A and C phase),three phase four wires should install 3 pcs CT(If only 2 CT,can consist other one phase current).
- Notice:In meter can set two kinds connection type,practice wiring type and inside set type must in consistent.or else the measure data is no exact in meter.

The detail wiring type,pulse constant those technical parameter according to product diagram.

V . programme operation

In programme status,digital interface adopt layers structure menu type,meter supply three lines number display(Fig.7)

No.1 line is First layer menu information;

No.2 line is second layer menu information;

No.3 line is third layer menu information;

ie: The right fig.7 show: No.1 layer:INPT signal input,No.2 layer:CT current change rated, No.3 layer:5 current CT value,mean set is current specification CT value=25/5A=5.



Fig.7

Table.5

No.1 Layer	No.2 Layer	No.3 Layer	Describe
System SET	Display DISP	0000-0017	0000 mean automatic in turn display(Each board connect see Table 6,7,8)
	DISL	0001-0003 或 0000-0120	0001-0003 is LED type light adjust; 0000-0120 is LCD aphelotropic display keep time (0000 is aphelotropic normal light)
	Energy Clear DATA CLr . E	1111	1111 mean energy clear, other value invalidation

Signal Input INPT	Wiring type NET	0000 or other value	0000 mean three phase four wires Other value is mean three phase three wires
	Voltage transformation ratio PT	1~9999	PT value:multiplicator primary value/second value
	Current transformation ratio CT	1~9999	CT value:multiplicator primary value/second value
Communication Set CON i (i is 1~2)	Address SN	1~247	meter address range 1~247
	Communication speed BAUD	0001~0004	0001 is 1200; 0002 is 2400; 0003 is 4800; 0004 is 9600
	Data format DATA	0001~0003	0001: N, 8, 1; 0002: 0, 8, 1; 0003: E, 8, 1
Relay output Set DO-i (i is 1~4)	Choose alarm item or close alarm (refer to 8.2 relay output)	Set alarm item's specific threshold value	Choose alarm item and Set relative threshold value (when alarm item is switch capacity, no need set threshold value), once meet alarm condition, switch output make
Transmitted output Set AO-i (i is 1~4)	Choose transmitter item or close transmitter (refer to 8.2 transmitter output)	Set transmitter item's full scale value	Choose transmitter item's and relative energy parameter (namely 0~20mA, 4~20mA, 4~12~20mA) Ie set to "AO-1" TYPE "D135" UAL "5000" is mean when A phase current 0~5A, relative first way 4~20mA's transmitter output signal

Notice: The above menu item is belong to complete functions item if user in use process found menu have some item less or useless, mean user choose the product no support this function.

Programme Set Steps (see fig.8)

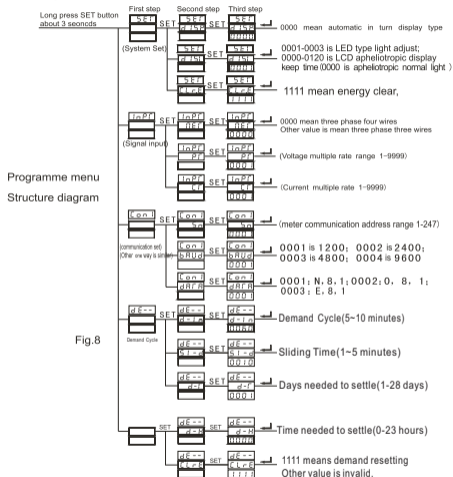
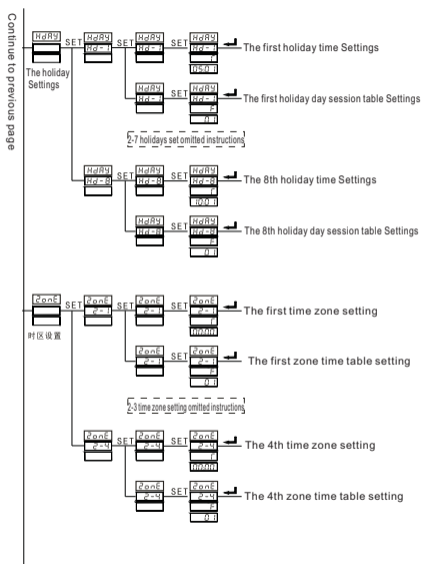
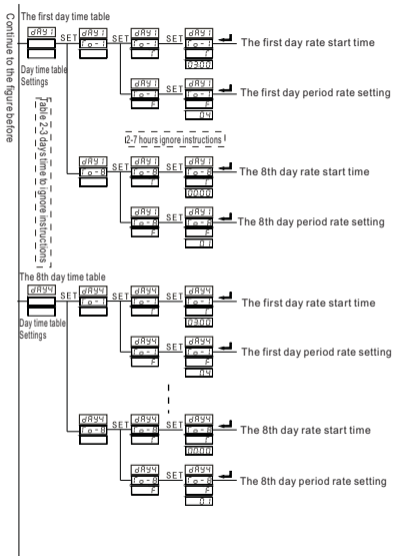
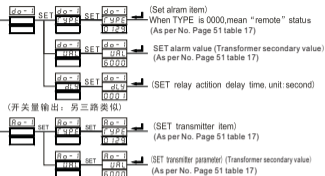
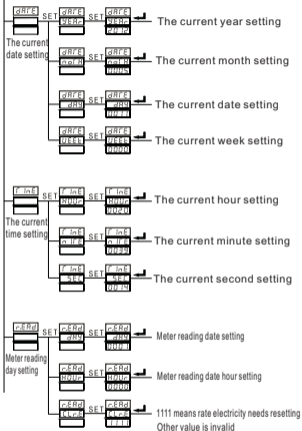

Fig.8





(Analog capacity output other three keys is similar)

Operation explain:

- After revised the third layer menu's data (or option), need press "SET" button to back the second menu then have effect.
- wiring type can according present practice wiring type to revise.
- in normal condition, the sticker of meter back have remark this meter model parameter and leave factory set parameter, user can according the practice demand to reset programme set.
- After revise value, through "◀" button and "▶" button increase or decrease, through "SET" button to move.

VI. Panel explain and measure information display

(1) Panel explain

If in display change over no relative information (or relative information useless) mean this model without this function

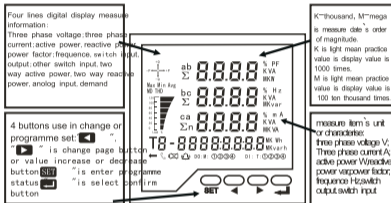

(2) Board display content (see table 6)

Board	Content	Explain
DISP=1 Three phase voltage active power kilowatt-hour		Separate display voltage U_a, U_b, U_c (in three phase four wires), forward active kilowatt-hour. In left Fig. $U_a=5774V$ $U_b=5774V$ $U_c=5774V$ Forward active power kilowatt-hour = 2908, 05 kWh

Table 6

DISP=2 Three phase voltage reverse active power kilowatt-hour		Separate display voltage U_{ab}, U_{bc}, U_{ca} (wires voltage, reverse active kilowatt-hour). In left fig: $U_{ab}=10kV$ $U_{bc}=10kV$ $U_{ca}=10kV$ reverse active kilowatt-hour. = 1000. 02 kWh
DISP=3 Three phase current peak active power kilowatt-hour		Display three phase current Ia, Ib, Ic, the unit is A, peak active watt-hour. In left fig: $I_a=5A$ $I_b=5A$ $I_c=5A$ Peak active watt-hour = 50.00 kWh
DISP=4 Total active power Total reactive power Total apparent power Reverse reactive power		Total active power = 86. 60 kW Total active power = 0000 Kvar Total apparent power = 86. 60 kVA Reverse reactive power = 100. 08 kWh

Table 6

<p>DISP=5</p> <p>A phase active power A phase reactive power A phase apparent power Forward active power</p>		<p>A phase active power =28.87kW A phase reactive power =0000Kvar A phase apparent power =28.87kVA Forward active power =2908.05kWh</p>
<p>DISP=6</p> <p>B phase active power B phase reactive power B phase apparent power Reserve active power</p>		<p>B phase active power =28.87kW B phase reactive power =0000Kvar B phase apparent power =28.87kVA Reserve active power =1000.02kWh</p>
<p>DISP=7</p> <p>C phase active power C phase reactive power C phase apparent power Peak active watt hour</p>		<p>C phase active power =28.87kW C phase reactive power =0000Kvar C phase apparent power =28.87kVA Peak active watt hour =50.00kWh</p>

Table 6

<p>DISP=8</p> <p>Average current Zero Sequence Current Peak active watt hour</p>		<p>In left Fig. display Average current =5A Zero Sequence Current=0.006A Peak active watt hour =50.00 kWh</p>
<p>DISP=9</p> <p>Three phase total power factor, frequency, voltage unbalancedness</p>		<p>In left fig. display Three phase total power factor=1.000 frequency=50Hz voltage unbalancedness=9V forward phase active kilowatt-hour =2908.05kWh</p>
<p>DISP=10</p> <p>split phase power factor</p>		<p>In left diagram a phase split phase power factor =0.999 b phase split phase power factor =0.999 c phase split phase power factor =0.999 Reverse phase active kilowatt-hour =1000.02kWh</p>

Table 6

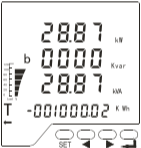
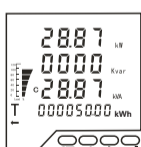

<p>DISP=11</p> <p>Phase voltage maximum demand total reactive watt hour</p>		<p>In the left fig: Phase voltage maximum demand =220.0 v total reactive watt hour =1000.02 kvarh</p>
<p>DISP=12</p> <p>Phase voltage maximum demand time, Peak reactive watt hour</p>		<p>In the left fig: Phase voltage maximum demand time =Dec 10th, 11 years 7 o'clock 5'9" Peak reactive watt hour =80.00kvarh</p>
<p>DISP=13</p> <p>Wire voltage maximum demand Peak reactive watt hour</p>		<p>In the left fig: Wire voltage maximum demand =380.0 v peak reactive watt hour =1000.02 kvarh</p>

Table 6

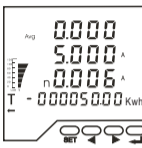
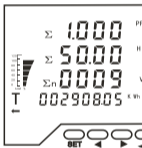
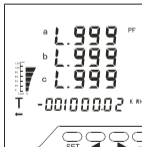

<p>DISP=14</p> <p>Time of wire voltage maximum demand Flat reactive watt hour</p>		<p>In the left fig: Time of wire voltage maximum demand =Dec 10th, 11 years 7 o'clock 5'9" Flat reactive watt hour =80.00 kvarh</p>
<p>DISP=15</p> <p>Current maximum demand valley reactive watt hour</p>		<p>In the left fig: Current maximum demand =5.000A valley reactive watt hour =80.00kvarh</p>
<p>DISP=16</p> <p>Time of current maximum demand Total reactive watt hour</p>		<p>In the left fig: Time of current maximum demand =Aug fifth, 11 years, 2 o'clock 3' 30" Total reactive watt hour =80.00kvarh</p>

Table 6

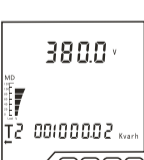
<p>DISP=17</p> <p>Active power maximum demand Sharp reactive watt hour</p>		<p>In the left fig: Active power maximum demand =3300 W Sharp reactive watt hour =1000.02kvarh</p>
<p>DISP=18</p> <p>Time of active power maximum demand Peak reactive watt hour</p>		<p>In the left fig: Time of active power maximum demand =Dec 17th, 11years, 9 o'clock 3'9" Peak reactive watt hour =80.00kvarh</p>
<p>DISP=19</p> <p>Reactive power maximum demand Flat reactive watt hour</p>		<p>In the left fig: Reactive power maximum demand =1000 var Flat reactive watt hour =1000.02kvarh</p>

Table 6



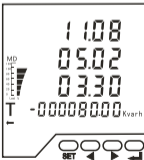

<p>DISP=20</p> <p>Time of reactive power maximum demand valley reactive watt hour</p>		<p>In the left fig: Time of reactive power maximum demand =Jan 12nd, 10 years, 1 o'clock 11' 4" valley reactive watt hour =80.00 kvarh</p>
<p>DISP=21</p> <p>Three phase voltage Current date</p>		<p>Separately display voltage Ua. Ub. Uc(3 phase 4 wire) current date. In the left fig Ua=5774V Ub=5774V Uc=5774V Current date =May 15th, 2011</p>
<p>DISP=22</p> <p>Three phase current Current time</p>		<p>Separately display current Ia. Ib. Ic, the unit is A Current time In the left figure: Ia=5A Ib=5A Ic=5A Current time =19 o'clock 23' 06"</p>

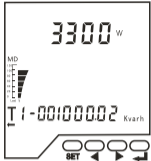
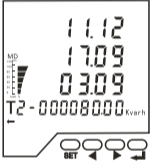
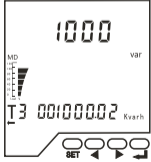
Table 6

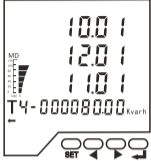

<p>DISP=23</p> <p>Total voltage harmonic</p>		<p>In the left fig: a. b. c phase total voltage harmonic =10%</p>
<p>DISP=24</p> <p>The second voltage harmonic</p>		<p>In the left fig: a. b. c phase the second voltage harmonic =10%</p>

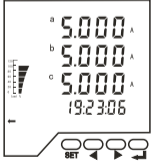
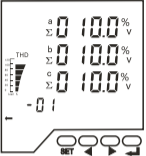
Omitted to

Omitted to

Omitted to

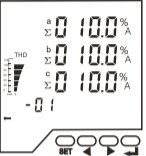
<p>DISP=53</p> <p>The 31st voltage harmonic</p>		<p>In the left fig: a. b. c phase the 31st voltage harmonic =10%</p>
---	---	--

<p>DISP=54</p> <p>Total current harmonic</p>		<p>In the left fig: a. b. c phase total current harmonic =10%</p>
<p>DISP=55</p> <p>The second current harmonic</p>		<p>In the left fig: a. b. c phase the second current harmonic =10%</p>

Omitted to

Omitted to

Omitted to

<p>DISP=84</p> <p>The 31st current harmonic</p>		<p>In the left fig: a. b. c phase the 31st current harmonic =10%</p>
---	--	--

Table 6

Table 6



<p>DISP = 14 Residual current</p>		<p>In left fig. show Residual current value: 0.09mA</p>
<p>DISP = 15 From 1 way to 12 way switch input information</p>		<p>First line:1-4 way channel communication Second Line:5-8 way channel communication Third line:9-12 way channel communication In left fig. display:No.5 way,No.6 way,No.8 way channel communication,pyer channel didn't make</p>
<p>DISP = 16 From 1 way to 4 way switch output information</p>		<p>In left fig. The second lines is effect information. The 1st way,3 rd way,4th way is channel make, the 2nd way is channel didn't make</p>

Table 8

VII. Communication protocol

7.1 physical layer

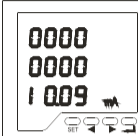
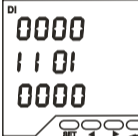
7.1.1 RS485 communication port,asynchronism semiduplex model;

7.1.2 communication speed 1200-9600bps can set,factory default 2400bps;

7.1.3 byte carry formate:1 bit is first bit,8 bit data bit,parity test(N81,E81,O81) can choose,leave
factory default E81.

7.2 Digital communication protocol:

meter supply serial asynchronism semiduplex RS 485 communication port,adopt MODBUS-
RTU agreement,each kinds data information both carry in communication circuit.In one line
circuit can connect more 32pcs network electric meter at same time,each pcs network meter
both can set different communication address.different series meter's communication connection
terminal number is different.communication connect should use with copper net's STP,stubs
size no less 0.5mm².In wiring should take the communication wire distance strong electric
cables or other strong electric field,recommend adopt T type network's connection tye(see fig. 12),
no suggest adopt Y-delta or other connection.

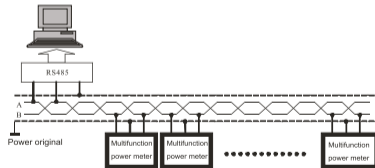
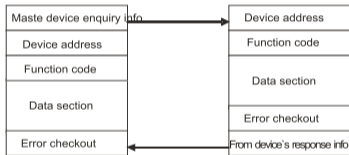

Fig.12

MODBUS_RTU communication agreement:

MODBUS agreement in one communication line adopt master-slave response mode. First master computer's signal will find only one address terminal device (slave PC), then terminal device send response signal, transmit opposite side to master PC, namely: in one lonely communication line, signal along with opposite two sides transmit whole communication data stream (semiduplex work mode). MODBUS agreement allow master (PC, PLC and so on) between terminal device communication (see fig. 13), disallow between lonely terminal device exchange the data, so each terminal device can't hold communication lines in initial period, only limit in respond to local enquiry signal.



Master PC enquiry:

Enquire information frame include device address code, function code, data information code, checkout code. Address code mean selected on slave PC device; function code is select slave device execute which function, like function code 03 or 04 is mean require from device to read register and back to their content; data section include slave device need execute function's other add-ons information, like in read command, data section's add-ons information from in which register begin to read and need read's register quantity; Checkout code use in check one frame information correctness, from slave device supply one validate information content if it's correct way, it adopt CRC16's checkout ruler.

Slave PC respond:

If slave PC bring one normal respond, in respond news get the slave address code, function code, data new code and CRC16 check out code. Data news code include the slave device collect the data: Like register value or status. If have error, we assume it is slave no do respond. Transmit type is mean one data frame one series independence data structure and transmit data's limit rule, below define MODBUS agree RTU type with compatible's transmit type. Each byte's bit: 1 pcs start bit, 8 pcs data bit, (parity check bit), 1 pcs stop bit (in parity checkout) or 1 pcs stop bit (no parity checkout bit).

Data frame's structure: message format) see Table 9

Table 9

Address	Function code	Data code	Checkout code
1 BYTE	1 BYTE	N BYTE	2 BYTE

Address code:

In frame beginning: One bit (8 bit binary code) consisted, decimal system is 0~255, in our system only use 1~247, other address is keep. This bit mark user point the terminal device's address, this device will receive from relative connection's master data. Each terminal device address must be uniquely, only was found address's terminal will respond include this address enquiry. When terminal send one respond, from the respond's slave address data can get which terminal is do communicate with it.

Function code: (see table 10)

Tell was found address's terminal execute in which function. Below table list support function code, and their mean and function.

Table 10

Code	Mean	Action
01	Read relay output status	Get relay output status
02	Remote switch capacity input status	Get switch capacity output news
03	Read data register value	
05	Remote single unit relay output action	
0F	Remote many units relay output action	Get one or more register's present binary system value
10H	Write preset register	Set binary system value in relative register

Checksum code:

Error checkout(CRC)field engross 2pcs bit,include one 16 bit's binary system value.CRC value count in transmit device,then additional to data frame,receiving device in receive data then over again count CRC value,then to compare to receive CRC field's value ,if two values no balance,then happen error.

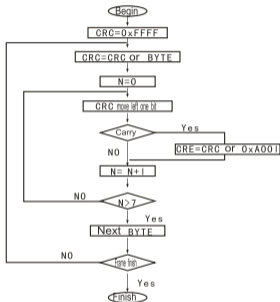

communication message for example:

Read data(function code:03);this function,user can get terminal device collection,record the data,and system parameter.Master once require collect data number no limit,but can't over define address range.The below example is from terminal device address is 12(0CH)'s slave PC,read 3 pcs data la,lb,lc(data frame's frame each address engross 2 byte,la's begin address is 43(2BH)begin,data length is 3 (03H)byte.

Enquiry data frame(Master PC)(as per Table 11)

Table 11

Address	command	origination register address (High)	origination register address (Low)	register quantity (High)	register quantity (Low)	CRC16 (Low)	CRC16 (High)
0CH	03H	00H	2BH	00H	03H	74H	DEH

Respond data frame(Slave PC)(as per Table 12)

Indicate la=1380H (4.992)、lb=1390H (5.008)、lc=1370H (4.976)。

Table 12

Address	command	Data length	Data 123456	CRC16 (Low)	CRC16 (High)
0CH	03H	06H	13H 80H 13H 90H 13H 70H	72H	E5H

Preset data(function code:16):this function allow to change some register's content(Energy meter can use this function to wrote,need emphasize the wrote date is can write property parameter,quantity no over address range,the below examples is write into current transformation ratio is 400A/ 5A=80 communication type.

Enquiry data frame(Master PC)(as per Table 13)

Table 13

Address	command	origination register address (High)	origination register address (Low)	register quantity (High)	register quantity (Low)	Write Data	CRC16 (Low)	CRC16 (High)
0CH	10H	00H	04H	00H	01H	00H 50H	FFH	78H

Respond data frame(Slave PC)indicate data already wrote into (as per Table 14)

Table 14

Address	command	origination register address (High)	origination register address (Low)	register quantity (High)	register quantity (Low)	CRC16 (Low)	CRC16 (High)
0CH	10H	00H	04H	00H	01H	41H	15H

MODBUS address message Table: (see table 15)

table 15

Add	Item	Description	Byte address	Explain
SET message				
1	DZ	meter address	2	one byte,1-254
	TXK	communication control bit	3	as per address explain
2	XSI	quantity of electric display select	4	keep
	SRS	wiring type select	5	as per address explain
3	PT	voltage multiple rate	6, 7	PT-Voltage 1 time test/2 times test(1-9999)
4	CT	current multiple rate	8, 9	CT-Current 1 time test/2 times test(1-9999)
5	DOS1	output 1 corresponding item	10	switch(analog quantity) corresponding item(see table 19)
	DOS2	output 2 corresponding item	11	switch(analog quantity) corresponding item(see table 19)
6	DOS1V	output 1 corresponding value	12, 13	switch(analog quantity) corresponding item(see table 19)
7	DOS2V	output 2 corresponding value	14, 15	switch(analog quantity) corresponding item(see table 19)
8	DOS3	output 3 corresponding item	16	switch(analog quantity) corresponding item(see table 19)
	DOS4	output 4 corresponding item	17	switch(analog quantity) corresponding item(see table 19)
9	DOS3V	output 3 corresponding value	18, 19	switch(analog quantity) corresponding item(see table 19)
10	DOS4V	output 4 corresponding value	20, 21	switch(analog quantity) corresponding item(see table 19)
11	DISP	boot-strap display	22	boot-strap display content(see Table 6.7.8)
	DISL	Show brightness adjust	23	Show brightness adjust 0001-0009(Only in LED display)
12	DOS1D	Switch capacity output 1 delay time	24	From over alarm value to switch action time (1-120S)
	DOS2D	Switch capacity output 2 delay time	25	From over alarm value to switch action time (1-120S)
13	DOS3D	Switch capacity output 3 delay time	26	From over alarm value to switch action time (1-120S)
	DOS4D	Switch capacity output 4 delay time	27	From over alarm value to switch action time (1-120S)
Running message				
33	DIO/Info	switch message	66, 67	0 break,1 make
35	DPT	voltage radix point position	70	
	DCT	current radix point position	71	
36	D PQ	power radix point position	72	
	S I G N	power symbol position	73	See Data format description
37	Ua	A phase voltage	74 75	Data count: Voltage U = (Rx / 10000) * (10 ^ DPT) Current I = (Rx / 10000) * (10 ^ DCT)
38	Ub	B phase voltage	76 77	
39	Uc	C phase voltage	78 79	
40	Uab	AB phase voltage	80 81	
41	Ubc	BC phase voltage	82 83	
42	Uca	CA phase voltage	84 85	
43	Ia	A phase current	86 87	
44	Ib	B phase current	88 89	
45	Ic	C phase current	90 91	
46	Pa	A phase active power	92 93	
47	Pb	B phase active power	94 95	

48	Pc	C phase active power	96 97	Power P = (Rx / 10000) * (10 ^ DPQ) Power factor PF = Rx / 1000 Frequency F = Rx / 100 Rx is corresponding register's data SIGN = 0 - 7 # separate mean Pa, Pb, Pc, Ps, Qa, Qb, Qc, Qs symbol, 1 is negative 0 is positive
49	Ps	Total active power	98 99	
50	Qa	A phase reactive power	100 101	
51	Qb	B phase reactive power	102 103	
52	Qc	C phase reactive power	104 105	
53	Qs	Total reactive power	106 107	
54	PFa	A phase power factor	108 109	
55	PFb	B phase power factor	110 111	
56	PFc	C phase power factor	112 113	
57	PFs	Total power factor	114 115	
58	Sa	A phase apparent power	116 117	
59	Sb	B phase apparent power	118 119	
60	Sc	C phase apparent power	120 121	
61	Ss	Total apparent power	122 123	
62	F	Frequency	124 125	
63 64	WPP	forward active power	126 127 128 129	secondary side energy parameter, energy data high byte at front, low byte at back, 4 byte is integral, unit is kWh(kVarh)
65 66	WPN	reverse active power	130 131 132 133	
67 68	WQP	forward reactive power	134 135 136 137	
69 70	WQN	reverse reactive power	138 139 140 141	
71 72	EPP	forward active power	142 143 144 145	first side energy parameter, adopt IEEE754 floating-point format, 4 byte length, unit kWh(kVarh)
73 74	EPN	reverse active power	146 147 148 149	
75 76	EQP	forward reactive power	150 151 152 153	
77 78	WQN	reverse reactive power	154 155 156 157	
Control word parts				
Parameter		Meaning		
communication control word TXKBIT7654;3210	Data format BIT5 BIT4	00 N. 8. 1		
		01 0. 8. 1		
Function: baud rate and format	Communication speed BIT1 BIT0	10 E. 8. 1		
		00 9600		
		01 4800		
		10 2400		
		11 1200		
meter work mode identifier SRS		BIT7		1-three phase four wires 1-three phase three wires

0037	PFb	B phase PF	Int16	2	R	
0038	PFc	C phase PF	Int16	2	R	
0039	PFs	Total PF	Int16	2	R	
003A	Sa	A phase apparent power	Int16	2	R	
003B	Sb	B phase apparent power	Int16	2	R	
003C	Sc	C phase apparent power	Int16	2	R	
003D	Ss	Total apparent power	Int16	2	R	
003E	F	Frequency	Int16	2	R	
003F	WPP	Forward active electricity	long	4	R	003F is high byte, the same with other
0040	WPN	Reverse active electricity	long	4	R	
0041	WQP	Forward reactive electricity	long	4	R	
0042	WQN	Reverse reactive electricity	long	4	R	
0043	EQP	Forward active electricity	float	4	R	
0044	EQN	Reverse active electricity	float	4	R	Secondary side energy parameter , energy data high byte at front, low byte at back, 4 byte is integral, unit is kWh(kvarh)
0045	EQP	Forward reactive electricity	float	4	R	
0046	EQN	Reverse reactive electricity	float	4	R	
0047	EQP	Forward active electricity	float	4	R	
0048	EQN	Reverse active electricity	float	4	R	
0049	EQP	Forward reactive electricity	float	4	R	First side energy parameter adopt IEEE754 floating-point format, 4 byte length, unit kwh(kvarh)
004A	EQN	Reverse reactive electricity	float	4	R	
004B	EQP	Forward active electricity	float	4	R	
004C	EQN	Reverse active electricity	float	4	R	
004D	EQP	Forward reactive electricity	float	4	R	
004E	EQN	Reverse reactive electricity	float	4	R	
Demand information						
0050		Demand cycle	Int16	2	R/W	
0051		Slippage time	Int16	2	R/W	
0052		Settle date day	char	1	R/W	
		Settle day hour	char	1	R/W	
0053		Currently voltage demand	Int16	2	R	
0054		Currently phase voltage demand	Int16	2	R	
0055		Currently current demand	Int16	2	R	
0056		Currently active power demand	Int16	2	R	
0057		Currently reactive power demand	Int16	2	R	
0060		Voltage max demand	Int16	2	R	

0061		Voltage max demand occur year	Int16	2	R	
0062		Voltage max demand occur month	char	1	R	
		Voltage max demand occur date	char	1	R	
0063		Voltage max demand occur hour	char	1	R	
		Voltage max demand occur minute	char	1	R	
0064		Voltage max demand occur second	char	1	R	
0065		Wire voltage max demand	Int16	2	R	
0066		Wire voltage max demand occur year	Int16	2	R	
0067		Wire voltage max demand occur month	char	1	R	
		Wire voltage max demand occur date	char	1	R	
0068		Wire voltage max demand occur hour	char	1	R	
		Wire voltage max demand occur minute	char	1	R	
0069		Wire voltage max demand occur second	char	1	R	
006a		Current max demand	Int16	2	R	
006b		Current max demand occur year	Int16	2	R	
006c		Current max demand occur month	char	1	R	
		Current max demand occur date	char	1	R	
006d		Current max demand occur hour	char	1	R	
		Current max demand occur minute	char	1	R	
006e		Current max demand occur second	char	1	R	
006f		Active power max demand	Int16	2	R	
0070		Active power max demand occur year	Int16	2	R	
0071		Active power max demand occur month	char	1	R	
		Active power max demand occur date	char	1	R	
0072		Active power max demand occur hour	char	1	R	
		Active power max demand occur minute	char	1	R	
0073		Active power max demand occur second	char	1	R	
0074		Reactive power max demand	Int16	2	R	
0075		Reactive power max demand occur year	Int16	2	R	
0076		Reactive power max demand occur month	char	1	R	
		Reactive power max demand occur date	char	1	R	
0077		Reactive power max demand occur hour	char	1	R	
		Reactive power max demand occur minute	char	1	R	

0078	Reactive power max demand occur second	char	1	R	
0079	Present month voltage max demand	Int16	2	R	
007a	Present month voltage max demand occur year	Int16	2	R	
007b	Present month voltage max demand occur month	char	1	R	
	Present month voltage max demand occur date	char	1	R	
007c	Present month voltage max demand occur hour	char	1	R	
	Present month voltage max demand occur minute	char	1	R	
007d	Present month voltage max demand occur second	char	1	R	
007e	Present month wire voltage max demand	Int16	2	R	
007f	Present month wire voltage max demand occur year	Int16	2	R	
0080	Present month wire voltage max demand occur month	char	1	R	
	Present month wire voltage max demand occur date	char	1	R	
0081	Present month wire voltage max demand occur hour	char	1	R	
	Present month wire voltage max demand occur minute	char	1	R	
0082	Present month wire voltage max demand occur second	char	1	R	
0083	Present month current max demand	Int16	2	R	
0084	Present month current max demand occur year	Int16	2	R	
0085	Present month current max demand occur month	char	1	R	
	Present month current max demand occur date	char	1	R	
0086	Present month current max demand occur hour	char	1	R	
	Present month current max demand occur minute	char	1	R	
0087	Present month current max demand occur second	char	1	R	
0088	Present month active power max demand	Int16	2	R	
0089	Present month active power max demand occur year	Int16	2	R	
008a	Present month active power max demand occur month	char	1	R	
	Present month active power max demand occur date	char	1	R	
008b	Present month active power max demand occur hour	char	1	R	
	Present month active power max demand occur minute	char	1	R	
008c	Present month active power max demand occur second	char	1	R	
008d	Present month reactive power max demand	Int16	2	R	
008e	Present month reactive power max demand occur year	Int16	2	R	
008f	Present month reactive power max demand occur month	char	1	R	

008f	Present month reactive power max demand occur date	char	1	R	
0090	Present month reactive power max demand occur hour	char	1	R	
	Present month reactive power max demand occur minute	char	1	R	
0091	Present month reactive power max demand occur second	char	1	R	
0092	Last month voltage max demand	Int16	2	R	
0093	Last month voltage max demand occur year	Int16	2	R	
0094	Last month voltage max demand occur month	char	1	R	
	Last month voltage max demand occur date	char	1	R	
0095	Last month voltage max demand occur hour	char	1	R	
	Last month voltage max demand occur minute	char	1	R	
0096	Last month voltage max demand occur second	char	1	R	
0097	Last month wire voltage max demand	Int16	2	R	
0098	Last month wire voltage max demand occur year	Int16	2	R	
0099	Last month wire voltage max demand occur month	char	1	R	
	Last month wire voltage max demand occur date	char	1	R	
009a	Last month wire voltage max demand occur hour	char	1	R	
	Last month wire voltage max demand occur minute	char	1	R	
009b	Last month wire voltage max demand occur second	char	1	R	
009c	Last month current max demand	Int16	2	R	
009d	Last month current max demand occur year	Int16	2	R	
009e	Last month current max demand occur month	char	1	R	
	Last month current max demand occur date	char	1	R	
009f	Last month current max demand occur hour	char	1	R	
	Last month current max demand occur minute	char	1	R	
00a0	Last month current max demand occur second	char	1	R	
00a1	Last month active power max demand	Int16	2	R	
00a2	Last month active power max demand occur year	Int16	2	R	
00a3	Last month active power max demand occur month	char	1	R	
	Last month active power max demand occur date	char	1	R	
00a4	Last month active power max demand occur hour	char	1	R	
	Last month active power max demand occur minute	char	1	R	
00a5	Last month active power max demand occur second	char	1	R	

00a6	Last month reactive power max demand	Int16	2	R	
00a7	Last month reactive power max demand occur year	Int16	2	R	
00a8	Last month reactive power max demand occur month	char	1	R	
00a9	Last month reactive power max demand occur date	char	1	R	
	Last month reactive power max demand occur hour	char	1	R	
00aa	Last month reactive power max demand occur minute	char	1	R	
	Last month reactive power max demand occur second	char	1	R	
00ab	The month before last voltage max demand	Int16	2	R	
00ac	The month before last voltage max demand occur year	Int16	2	R	
00ad	The month before last voltage max demand occur month	char	1	R	
	The month before last voltage max demand occur date	char	1	R	
00ae	The month before last voltage max demand occur hour	char	1	R	
	The month before last voltage max demand occur minute	char	1	R	
00af	The month before last voltage max demand occur second	char	1	R	
00b0	The month before last wire voltage max demand	Int16	2	R	
00b1	The month before last wire voltage max demand occur year	Int16	2	R	
00b2	The month before last wire voltage max demand occur month	char	1	R	
	The month before last wire voltage max demand occur date	char	1	R	
00b3	The month before last wire voltage max demand occur hour	char	1	R	
	The month before last wire voltage max demand occur minute	char	1	R	
00b4	The month before last wire voltage max demand occur second	char	1	R	
00b5	The month before last current max demand	Int16	2	R	
00b6	The month before last current max demand occur year	Int16	2	R	
00b7	The month before last current max demand occur month	char	1	R	
	The month before last current max demand occur date	char	1	R	
00b8	The month before last current max demand occur hour	char	1	R	
	The month before last current max demand occur minute	char	1	R	
00b9	The month before last current max demand occur second	char	1	R	
00ba	The month before last active power max demand	Int16	2	R	
00bb	The month before last active power max demand occur year	Int16	2	R	
00bc	The month before last active power max demand occur month	char	1	R	
	The month before last active power max demand occur date	char	1	R	

00bd	The month before last active power max demand occur hour	char	1	R	
	The month before last active power max demand occur minute	char	1	R	
00be	The month before last active power max demand occur second	char	1	R	
00bf	The month before last reactive power max demand	Int16	2	R	
00c0	The month before last reactive power max demand occur year	Int16	2	R	
00c1	The month before last reactive power max demand occur month	char	1	R	
	The month before last reactive power max demand occur date	char	1	R	
00c2	The month before last reactive power max demand occur hour	char	1	R	
	The month before last reactive power max demand occur minute	char	1	R	
00c3	The month before last reactive power max demand occur second	char	1	R	
00c4	Current voltage max demand	Int16	2	R	
00c5	Current wire voltage max demand	Int16	2	R	
00c6	Current current max demand	Int16	2	R	
00c7	Current active power max demand	Int16	2	R	
00c8	Current reactive power max demand	Int16	2	R	
Multiple rate					
0100	The first day table first hours starting time	BCD	2	R/W	hh:mm
0101	The first day table first hours starting rate	char	2	R/W	Number 1,2,3 corresponding peak talka period time
0102	The first day table second hours starting time	BCD	2	R/W	hh:mm
0103	The first day table second hours starting rate	char	2	R/W	Number 1,2,3 corresponding peak talka period time
0104	The first day table third hours starting time	BCD	2	R/W	hh:mm
0105	The first day table third hours starting rate	char	2	R/W	Number 1,2,3 corresponding peak talka period time
0106	The first day table fourth hours starting time	BCD	2	R/W	hh:mm
0107	The first day table fourth hours starting rate	char	2	R/W	Number 1,2,3 corresponding peak talka period time
0108	The first day table fifth hours starting time	BCD	2	R/W	hh:mm
0109	The first day table fifth hours starting rate	char	2	R/W	Number 1,2,3 corresponding peak talka period time
010A	The first day table sixth hours starting time	BCD	2	R/W	hh:mm
010B	The first day table sixth hours starting rate	char	2	R/W	Number 1,2,3 corresponding peak talka period time
010C	The first day table seventh hours starting time	BCD	2	R/W	hh:mm
010D	The first day table seventh hours starting rate	char	2	R/W	Number 1,2,3 corresponding peak talka period time
010E	The first day table eighth hours starting time	BCD	2	R/W	hh:mm
010F	The first day table eighth hours starting rate	char	2	R/W	Number 1,2,3 corresponding peak talka period time

0110-011F	The second day time table data	Corresponding (0x11000x011F) data format (this item is select function)				
0120-012F	The third day time table data	Corresponding (0x11000x011F) data format (this item is select function)				
0130-013F	The fourth day time table data	Corresponding (0x11000x011F) data format (this item is select function)				
0140	The first holiday date	BCD	2	R/W	MM:DD	
0141	The first holiday day time table	char	2	R/W	Number 1,2,3,4 corresponding 1,2,3,4,time table	
0142	The second holiday date	BCD	2	R/W	MM:DD	
0143	The second holiday day time table	char	2	R/W	Number 1,2,3,4 corresponding 1,2,3,4,time table	
0144	The third holiday date	BCD	2	R/W	MM:DD	
0145	The third holiday day time table	char	2	R/W	Number 1,2,3,4 corresponding 1,2,3,4,time table	
0146	The fourth holiday date	BCD	2	R/W	MM:DD	
0147	The fourth holiday day time table	char	2	R/W	Number 1,2,3,4 corresponding 1,2,3,4,time table	
0148	The fifth holiday date	BCD	2	R/W	MM:DD	
0149	The fifth holiday day time table	char	2	R/W	Number 1,2,3,4 corresponding 1,2,3,4,time table	
014A	The sixth holiday date	BCD	2	R/W	MM:DD	
014C	The seventh holiday date	BCD	2	R/W	MM:DD	
014D	The seventh holiday day time table	char	2	R/W	Number 1,2,3, corresponding 1,2,3,time table	
014E	The eighth holiday date	BCD	2	R/W	MM:DD	
014F	The eight holiday day time table	char	2	R/W	Number 1,2,3, corresponding 1,2,3,time table	
0150	First section start date	BCD	2	R/W	MM:DD	
0151	First section time table number	char	2	R/W	Number 1,2,3, corresponding 1,2,3,time table	
0152	Second section time start date	BCD	2	R/W	MM:DD	
0153	Second section time table date	char	2	R/W	Number 1,2,3, corresponding 1,2,3,time table	
0154	The third section start date	BCD	2	R/W	MM:DD	
0155	The third section time table date	char	2	R/W	Number 1,2,3, corresponding 1,2,3,time table	
0166,0167	Data week	BCD	4	R/W	YY:MM:DD:WW	
0168,0169	time	BCD	4	R/W	00:hh:mm:ss	
016A	Meter reading date	BCD	2	R/W	DD:hh	
0240,0241		long	4	R/W	2 times test present positive active power total quantity of electricity	
0242,0243		long	4	R/W	2 times test present positive active power tip quantity of electricity	
0244,0245		long	4	R/W	2 times test present positive active power peak quantity of electricity	
0246,0247		long	4	R/W	2 times test present positive active power flat quantity of electricity	
0248,0249		long	4	R/W	2 times test present positive active power valley quantity of electricity	

024A,024B		long	4	R	2 times test present negative active power flat quantity of electricity	
024C,024D		long	4	R	2 times test present negative active power flat quantity of electricity	
024E,024F		long	4	R	2 times test present negative active power flat quantity peak of electricity	
0250,0251		long	4	R	2 times test present negative power flat quantity of electricity	
0252,0253		long	4	R	2 times test present negative power valley quantity of electricity	
0254,0255		long	4	R	2 times test present positive power flat quantity of electricity	
0256,0257		long	4	R	2 times test present positive reactive tip power	
0258,0259		long	4	R	2 times test present positive reactive peak power	
025A,025B		long	4	R	2 times test present positive reactive flat power	
025C,025D		long	4	R	2 times test present positive reactive valley power	
025E,025F		long	4	R	2 times test present negative reactive total power	
0260,0261		long	4	R	2 times test present negative reactive tip power	
0262,0263		long	4	R	2 times test present negative reactive peak power	
0264,0265		long	4	R	2 times test present negative reactive flat power	
0266,0267		long	4	R	2 times test present negative reactive valley power	
0268,0269		long	4	R	2 times test present 1 quadrant reactive total power	
026A,026B		long	4	R	2 times test present 1 quadrant reactive tip power	
026C,026D		long	4	R	2 times test present 1 quadrant reactive peak power	
026E,026F		long	4	R	2 times test present 1 quadrant reactive flat power	
0270,0271		long	4	R	2 times test present 1 quadrant reactive valley power	
0272,0273		long	4	R	2 times test present 4 quadrant reactive total power	
0274,0275		long	4	R	2 times test present 4 quadrant reactive total power	
0276,0277		long	4	R	2 times test present 4 quadrant reactive peak power	
0278,0279		long	4	R	2 times test present 4 quadrant reactive flat power	
027A,027B		long	4	R	2 times test present 4 quadrant reactive valley power	
027C,027D		long	4	R	2 times test present 2 quadrant reactive total power	
027E,027F		long	4	R	2 times test present 4 quadrant reactive tip power	
0280,0281		long	4	R	2 times test present 4 quadrant reactive peak power	
0282,0283		long	4	R	2 times test present 4 quadrant reactive flat power	
0284,0285		long	4	R	2 times test present 4 quadrant reactive valley power	
0286,0287		long	4	R	2 times test present 3 quadrant reactive total power	
0288,0289		long	4	R	2 times test present 4 quadrant reactive tip power	
028A,028B		long	4	R	2 times test present 4 quadrant reactive peak power	

028C, 028D		long	4	R	2 times test present 4 quadrant reactive flat power
028E, 028F		long	4	R	2 times test present 4 quadrant reactive valley power
0290, 0291		long	4	R	2 times test last month positive active total power
0292, 0293		long	4	R	2 times test last month positive active tip power
0294, 0295		long	4	R	2 times test last month positive active peak power
0296, 0297		long	4	R	2 times test last month positive active flat power
0298, 0299		long	4	R	2 times test last month positive active valley power
029A, 029B		long	4	R	2 times test last month negative active total power
029C, 029D		long	4	R	2 times test last month negative active tip power
029E, 029F		long	4	R	2 times test last month negative active peak power
02A0, 02A1		long	4	R	2 times test last month negative active flat power
02A2, 02A3		long	4	R	2 times test last month negative active valley power
02A4, 02A5		long	4	R	2 times test last month positive reactive total power
02A6, 02A7		long	4	R	2 times test last month positive reactive tip power
02A8, 02A9		long	4	R	2 times test last month positive reactive peak power
02AA, 02AB		long	4	R	2 times test last month positive reactive flat power
02AC, 02AD		long	4	R	2 times test last month positive reactive valley power
02AE, 02AF		long	4	R	2 times test last month negative reactive total power
02B0, 02B1		long	4	R	2 times test last month negative reactive tip power
02B2, 02B3		long	4	R	2 times test last month negative reactive peak power
02B4, 02B5		long	4	R	2 times test last month negative reactive flat power
02B6, 02B7		long	4	R	2 times test last month negative reactive valley power
02B8, 02B9		long	4	R	2 times test last month 1 quadrant reactive total power
02BA, 02BB		long	4	R	2 times test last month 1 quadrant reactive tip power
02BC, 02BD		long	4	R	2 times test last month 1 quadrant reactive peak power
02BE, 02BF		long	4	R	2 times test last month 1 quadrant reactive flat power
02C0, 02C1		long	4	R	2 times test last month 1 quadrant reactive valley power
02C2, 02C3		long	4	R	2 times test last month 4 quadrant reactive total power
02C4, 02C5		long	4	R	2 times test last month 4 quadrant reactive tip power
02C6, 02C7		long	4	R	2 times test last month 4 quadrant reactive peak power
02C8, 02C9		long	4	R	2 times test last month 4 quadrant reactive flat power
02CA, 02CB		long	4	R	2 times test last month 4 quadrant reactive valley power
02CC, 02CD		long	4	R	2 times test last month 2 quadrant reactive total power

02CE, 02CF		long	4	R	2 times test last month 2 quadrant reactive tip power
02D0, 02D1		long	4	R	2 times test last month 2 quadrant reactive peak power
02D2, 02D3		long	4	R	2 times test last month 2 quadrant reactive flat power
02D4, 02D5		long	4	R	2 times test last month 3 quadrant reactive valley power
02D6, 02D7		long	4	R	2 times test last month 3 quadrant reactive valley power
02D8, 02D9		long	4	R	2 times test last month 3 quadrant reactive total power
02DA, 02DB		long	4	R	2 times test last month 3 quadrant reactive tip power
02DC, 02DD		long	4	R	2 times test last month 3 quadrant reactive flat power
02DE, 02DF		long	4	R	2 times test last month 3 quadrant reactive valley power
02E0, 02E1		long	4	R	2 times test the month last before positive active total power
02E2, 02E3		long	4	R	2 times test the month last before positive active tip power
02E4, 02E5		long	4	R	2 times test the month last before positive active peak power
02E6, 02E7		long	4	R	2 times test the month last before positive active flat power
02E8, 02E9		long	4	R	2 times test the month last before positive active valley power
02EA, 02EB		long	4	R	2 times test the month last before negative active total power
02EC, 02ED		long	4	R	2 times test the month last before negative active tip power
02EE, 02EF		long	4	R	2 times test the month last before negative active peak power
02F0, 02F1		long	4	R	2 times test the month last before negative active flat power
02F2, 02F3		long	4	R	2 times test the month last before negative active valley power
02F4, 02F5		long	4	R	2 times test the month last before positive reactive total power
02F6, 02F7		long	4	R	2 times test the month last before positive reactive tip power
02F8, 02F9		long	4	R	2 times test the month last before positive reactive peak power
02FA, 02FB		long	4	R	2 times test the month last before positive reactive flat power
02FC, 02FD		long	4	R	2 times test the month last before positive reactive valley power
02FE, 02FF		long	4	R	2 times test the month last before negative reactive total power
0300, 0301		long	4	R	2 times test the month last before negative reactive tip power
0302, 0303		long	4	R	2 times test the month last before negative reactive peak power
0304, 0305		long	4	R	2 times test the month last before negative reactive flat power
0306, 0307		long	4	R	2 times test the month last before negative reactive valley power
0308, 0309		long	4	R	2 times test the month last before 1 quadrant reactive total power
030A, 030B		long	4	R	2 times test the month last before 1 quadrant reactive tip power
030C, 030D		long	4	R	2 times test the month last before 1 quadrant reactive peak power
030E, 030F		long	4	R	2 times test the month last before 1 quadrant reactive flat power

0310, 0311		long	4	R	2 times test the month last before 1 quadrant reactive valley power
0312, 0313		long	4	R	2 times test the month last before 4 quadrant reactive total power
0314, 0315		long	4	R	2 times test the month last before 1 quadrant reactive tip power
0316, 0317		long	4	R	2 times test the month last before 1 quadrant reactive peak power
0318, 0319		long	4	R	2 times test the month last before 1 quadrant reactive flat power
031A, 031B		long	4	R	2 times test the month last before 1 quadrant reactive valley power
031C, 031D		long	4	R	2 times test the month last before 2 quadrant reactive total power
031E, 031F		long	4	R	2 times test the month last before 2 quadrant reactive tip power
0320, 0321		long	4	R	2 times test the month last before 2 quadrant reactive peak power
0322, 0323		long	4	R	2 times test the month last before 2 quadrant reactive flat power
0324, 0325		long	4	R	2 times test the month last before 2 quadrant reactive valley power
0326, 0327		long	4	R	2 times test the month last before 3 quadrant reactive total power
0328, 0329		long	4	R	2 times test the month last before 3 quadrant reactive tip power
032A, 032B		long	4	R	2 times test the month last before 3 quadrant reactive peak power
032C, 032D		long	4	R	2 times test the month last before 3 quadrant reactive flat power
032E, 032F		long	4	R	2 times test the month last before 3 quadrant reactive valley power
040, 041		float	4	R	1 time test present positive active total power
042, 043		float	4	R	1 time test present positive active tip power
044, 045		float	4	R	1 time test present positive active peak power
046, 047		float	4	R	1 time test present positive active flat power
048, 049		float	4	R	1 time test present positive active valley power
04A, 04B		float	4	R	1 time test present positive active total power
04C, 04D		float	4	R	1 time test present negative active tip power
04E, 04F		float	4	R	1 time test present negative active peak power
040, 041		float	4	R	1 time test present negative active flat power
042, 043		float	4	R	1 time test present negative active valley power
044, 045		float	4	R	1 time test present positive re active total power
046, 047		float	4	R	1 time test present positive re active tip power
048, 049		float	4	R	1 time test present positive re active peak power
04A, 04B		float	4	R	1 time test present positive re active flat power
04C, 04D		float	4	R	1 time test present positive re active valley power
04E, 04F		float	4	R	1 time test present negative re active total power
040, 041		float	4	R	1 time test present negative re active tip power

0462, 0463		float	4	R	1 time test present negative re active peak power
0464, 0465		float	4	R	1 time test present negative re active flat power
0466, 0467		float	4	R	1 time test present negative re active valley power
0468, 0469		float	4	R	1 time test present 1 quadrant negative total power
046A, 046B		float	4	R	1 time test present 2 quadrant negative tip power
046C, 046D		float	4	R	1 time test present 1 quadrant negative peak power
046E, 046F		float	4	R	1 time test present 1 quadrant negative flat power
0470, 0471		float	4	R	1 time test present 2 quadrant negative valley power
0472, 0473		float	4	R	1 time test present 4 quadrant negative total power
0474, 0475		float	4	R	1 time test present 4 quadrant negative tip power
0476, 0477		float	4	R	1 time test present 4 quadrant negative peak power
0478, 0479		float	4	R	1 time test present 4 quadrant negative flat power
047A, 047B		float	4	R	1 time test present 4 quadrant negative valley power
047C, 047D		float	4	R	1 time test present 2 quadrant negative total power
047E, 047F		float	4	R	1 time test present 2 quadrant negative tip power
0480, 0481		float	4	R	1 time test present 2 quadrant negative peak power
0482, 0483		float	4	R	1 time test present 2 quadrant negative flat power
0484, 0485		float	4	R	1 time test present 2 quadrant negative valley power
0486, 0487		float	4	R	1 time test present 3 quadrant negative total power
0488, 0489		float	4	R	1 time test present 3 quadrant negative tip power
048A, 048B		float	4	R	1 time test present 3 quadrant negative peak power
048C, 048D		float	4	R	1 time test present 3 quadrant negative flat power
048E, 048F		float	4	R	1 time test present 3 quadrant negative valley power
0490, 0491		float	4	R	1 time test last month positive active total power
0492, 0493		float	4	R	1 time test last month positive active tip power
0494, 0495		float	4	R	1 time test last month positive active peak power
0496, 0497		float	4	R	1 time test last month positive active flat power
0498, 0499		float	4	R	1 time test last month positive active valley power
049A, 049B		float	4	R	1 time test last month negative active total power
049C, 049D		float	4	R	1 time test last month negative active tip power
049E, 049F		float	4	R	1 time test last month negative active peak power
04A0, 04A1		float	4	R	1 time test last month negative active flat power
04A2, 04A3		float	4	R	1 time test last month negative active valley power

02A4, 02A5		float	4	R	1 time test last month positive reactive total power
04A6, 04A7		float	4	R	1 time test last month positive reactive tip power
04A8, 04A9		float	4	R	1 time test last month positive reactive peak power
04AA, 04AB		float	4	R	1 time test last month positive reactive flat power
04AC, 04AD		float	4	R	1 time test last month positive reactive valley power
04AE, 04AF		float	4	R	1 time test last month negative reactive total power
04B0, 04B1		float	4	R	1 time test last month negative reactive tip power
04B2, 04B3		float	4	R	1 time test last month negative reactive peak power
04B4, 04B5		float	4	R	1 time test last month negative reactive flat power
04B6, 04B7		float	4	R	1 time test last month negative reactive valley power
04B8, 04B9		float	4	R	1 time test last month 1 quadrant reactive total power
04BA, 04BB		float	4	R	1 time test last month 1 quadrant reactive peak power
04BC, 04BD		float	4	R	1 time test last month 1 quadrant reactive flat power
04BE, 04BF		float	4	R	1 time test last month 1 quadrant reactive valley power
04C0, 04C1		float	4	R	1 time test last month 4 quadrant reactive total power
04C2, 04C3		float	4	R	1 time test last month 4 quadrant reactive tip power
04C4, 04C5		float	4	R	1 time test last month 4 quadrant reactive peak power
04C6, 04C7		float	4	R	1 time test last month 4 quadrant reactive flat power
04C8, 04C9		float	4	R	1 time test last month 4 quadrant reactive valley power
04CA, 04CB		float	4	R	1 time test last month positive reactive total power
04CC, 04CD		float	4	R	1 time test last month positive reactive tip power
04CE, 04CF		float	4	R	1 time test last month positive active peak power
04D0, 04D1		float	4	R	1 time test last month 2 quadrant reactive flat power
04D2, 04D3		float	4	R	1 time test last month positive reactive valley power
04D4, 04D5		float	4	R	1 time test last month 3 quadrant reactive total power
04D6, 04D7		float	4	R	1 time test last month 3 quadrant reactive tip power
04D8, 04D9		float	4	R	1 time test last month 3 quadrant reactive peak power
04DA, 04DB		float	4	R	1 time test last month 3 quadrant reactive flat power
04DC, 04DD		float	4	R	1 time test last month 3 quadrant reactive valley power
04DE, 04DF		float	4	R	1 time test the month before last positive active total power
04E0, 04E1		float	4	R	1 time test the month before last positive active tip power
04E2, 04E3		float	4	R	1 time test the month before last positive active peak power
04E4, 04E5		float	4	R	1 time test the month before last positive active flat power

04E6, 04E7		float	4	R	1 time test the month before last positive active valley power
04E8, 04E9		float	4	R	1 time test the month before last negative active total power
04EA, 04EB		float	4	R	1 time test the month before last negative active tip power
04EC, 04ED		float	4	R	1 time test the month before last negative active peak power
04EE, 04EF		float	4	R	1 time test the month before last negative active flat power
04F0, 04F1		float	4	R	1 time test the month before last negative active valley power
04F2, 04F3		float	4	R	1 time test the month before last positive reactive total power
04F4, 04F5		float	4	R	1 time test the month before last positive reactive tip power
04F6, 04F7		float	4	R	1 time test the month before last positive reactive peak power
04F8, 04F9		float	4	R	1 time test the month before last positive reactive flat power
04FA, 04FB		float	4	R	1 time test the month before last positive reactive valley power
04FC, 04FD		float	4	R	1 time test the month before last negative reactive total power
04FE, 04FF		float	4	R	1 time test the month before last negative reactive tip power
0500, 0501		float	4	R	1 time test the month before last negative reactive peak power
0502, 0503		float	4	R	1 time test the month before last negative reactive flat power
0504, 0505		float	4	R	1 time test the month before last negative reactive valley power
0506, 0507		float	4	R	1 time test the month before last negative reactive 1 quadrant total power
0508, 0509		float	4	R	1 time test the month before last negative reactive 1 quadrant tip power
050A, 050B		float	4	R	1 time test the month before last negative reactive 1 quadrant peak power
050C, 050D		float	4	R	1 time test the month before last negative reactive 1 quadrant flat power
050E, 050F		float	4	R	1 time test the month before last negative reactive 1 quadrant valley power
0510, 0511		float	4	R	1 time test the month before last negative reactive 4 quadrant total power
0512, 0513		float	4	R	1 time test the month before last negative reactive 4 quadrant tip power
0514, 0515		float	4	R	1 time test the month before last negative reactive 4 quadrant peak power
0516, 0517		float	4	R	1 time test the month before last negative reactive 4 quadrant flat power
0518, 0519		float	4	R	1 time test the month before last negative reactive 4 quadrant valley power
051A, 051B		float	4	R	1 time test the month before last negative reactive 2 quadrant total power
051C, 051D		float	4	R	1 time test the month before last negative reactive 2 quadrant tip power
051E, 051F		float	4	R	1 time test the month before last negative reactive 2 quadrant peak power
0520, 0521		float	4	R	1 time test the month before last negative reactive 2 quadrant flat power
0522, 0523		float	4	R	1 time test the month before last negative reactive 2 quadrant valley power
0524, 0525		float	4	R	1 time test the month before last negative reactive 2 quadrant active power
0526, 0527		float	4	R	1 time test the month before last negative reactive 3 quadrant total power

0528, 0529		float	4	R	Time test the month before last negative reactive (quarter) (p. power
052A, 052B		float	4	R	Time test the month before last negative reactive (quarter) (peak power
052C, 052D		float	4	R	Time test the month before last negative reactive (quarter) (at power
052E, 052F		float	4	R	Time test the month before last negative reactive (quarter) (at power
Harmonic					
0180	A phase component of AC voltage	Int16	2	R	Data format information : for example :read data is 0x04d2,switch to decimal system is 1234,then in fact harmonic component is 12.34%.
0181	A phase component of total harmonic	Int16	2	R	
0182	A phase 2times test harmonic	Int16	2	R	
0183	A phase 3times test harmonic	Int16	2	R	
0184	A phase 4times test harmonic	Int16	2	R	
0185	A phase 5times test harmonic	Int16	2	R	
0186	A phase 6times test harmonic	Int16	2	R	
0187	A phase 7times test harmonic	Int16	2	R	
0188	A phase 8times test harmonic	Int16	2	R	
0189	A phase 9times test harmonic	Int16	2	R	
018A	A phase 10times test harmonic	Int16	2	R	
018B	A phase 11times test harmonic	Int16	2	R	
018C	A phase 12times test harmonic	Int16	2	R	
018D	A phase 13times test harmonic	Int16	2	R	
018E	A phase 14times test harmonic	Int16	2	R	
018F	A phase 15times test harmonic	Int16	2	R	
0190	A phase 16times test harmonic	Int16	2	R	
0191	A phase 17times test harmonic	Int16	2	R	
0192	A phase 18times test harmonic	Int16	2	R	
0193	A phase 19times test harmonic	Int16	2	R	
0194	A phase 20times test harmonic	Int16	2	R	
0195	A phase 21times test harmonic	Int16	2	R	
0196	A phase 22times test harmonic	Int16	2	R	
0197	A phase 23times test harmonic	Int16	2	R	
0198	A phase 24times test harmonic	Int16	2	R	
0199	A phase 25times test harmonic	Int16	2	R	
019A	A phase 26times test harmonic	Int16	2	R	
019B	A phase 27times test harmonic	Int16	2	R	

019C	A phase 28times test harmonic	Int16	2	R	
019D	A phase 29 times harmonic	Int16	2	R	
019E	A phase 30 times harmonic	Int16	2	R	
019F	A phase 31 times test harmonic	Int16	2	R	
01A0-01BF	A phase harmonic data	Int16		R	Data format corresponding A phase voltage harmonic data
01C0-01DF	B phase voltage harmonic data	Int16		R	Data format corresponding B phase voltage harmonic data
01E0-01FF	B phase current harmonic data	Int16		R	Data format corresponding B phase voltage harmonic data
0200-021F	C phase voltage harmonic data	Int16		R	Data format corresponding A phase voltage harmonic data
0220-023F	C phase current harmonic data	Int16		R	Data format corresponding A phase voltage harmonic data
Parameter		Meaning			
communication control word TXKBIT7654;3210 Function: baud rate and format		Data format BIT 5 BIT 4		00 N. 8. 1	
				01 0. 8. 1	
		Communication speed BIT 1 BIT 0		10 E. 8. 1	
				00 9600	
				01 4800	
meter work mode identifier SRS		BIT 7		10 2400	
				11 1200	

8.Function output

8.1 Energy measure and pulse output

This series meter adopt 3 row 12 bit digital to display once energy,VH-0 show total active power,VH-1 show reverse active power,VAHO show reverse reactive power,VAH1 show reverse reactive power,pulse normal value is 8000imp/kwh.

8.2 switch capacity,transmit module part:

This series meter supply 4 ways switch capacity input function and 4 ways switch capacity output function,4 ways switch input adopt dry contact resistance switch signal input type,meter inside prepare 12V work power,no need outside supply power source.When outside is make,go through meter switch input module DI collect is make message,show 1;when outside is break,go through meter switch input module DI collect is break message show 0.switch input module not only can collect and display local switch message,and meanwhile can through meter's digital port RS485 come true remote transmit function,namely"remote communication"function";4 way optical relay's switch output function,relay output is make,show 1, when in switch output is closed,relay output is break,show 0.

8.2.1 electric parameter

switch input DI:make resistance R<5000;closed break resistance>100KΩ
switch output DO:AC 250V,0.1A

8.2.2 Register:(see Table 16)

DIO message register(address 33):this register mean 4 ways switch input and 4 way switch output status message. (see Table 16)

DI Or register	BIT7	BIT6	BIT5	BIT4	BIT3	BIT2	BIT1	BIT0
Corresponding switch port	D04	D03	D02	D01	D14	D13	D12	D11
Reset	0	0	0	0	0	0	0	0

DIO message register's low 4 bit(BIT3,BIT 2,BIT 1,BIT 0)is switch input status message.If register content is 0 000 0 1 0 1 mean switch input port 1,3 way is make;2、4 way is close break;DIO message register's high 4 bit(BIT 7,BIT 6,BIT 5,BIT 4) is switch output status message.If register's content is 1 1 0 1 0 0 0 mean port 15 and 16,19 and 20,21 and 22 make;17 and 18 closed break,all DIO message in meter board can show.If first way adopt address is 10、11、12 (BYTE2、 BYTE1、 BYTE0) 3pcs byte to save.Address lowest byte(address 10)save alarm output.

Object's parameter,like Ua's low alarm parameter is 1,high alarm parameter is 129;0 is mean remote mode,other 2 byte(address 11、12) is alarm over limit parameter.Other 3 ways is similar.Corresponding address space can as per the table(See table 7)

Item	Variable	Mean: DOSi (BYTE2、 BYTE1、 BYTE0)
Switch output 1	DOS1	BYTE2(1-255),alarm's item,1-26 separate corresponding energy address is corresponding 26 pcs measure energy low alarm,over 12 of 28 9-154 is corresponding a high alarm,0 mean keep type,detail as per switch capacity output,transmit output energy parameter parallel table BYTE1 0 (1-9999),alarm limit parameter,parameter from same energy message,notice the radix point meaning.
Switch output 2	DOS2	
Switch output 3	DOS3	
Switch output 4	DOS4	

Table 17

8.2.3 Application example:

A.switch input function:

Switch module have 1 2 way switch input collect function.After input signal,meter panel board show"make 1" or "break 0" message.use in switch signal's local monitor.Take the meter change to switch message display status,meanwhile "DI" indication light is light,detail as per No. Page 17 DISP=12,No.page DISP=15 diagram.Through meter RS485 digital port,can take switch message register(DIO) message transmit to remote PC end terminal.

B. switch output,analog output function:

Remote function:Through upper machine to D1 0 message register wrote control message,can control 4 way switch output port's make and break,wrote 1 corresponding port make.wrote 0 corresponding port break.If write enter binary system 1 0 1 1 0000,mean 1 way,3 way,4 way output port make,3 way is break.This function can't with switch output module's other over limit alarm output function use in same time,if use remote function,need set the energy object's parameter set is 0,and close alarm output function,when meter in switch capacity output function setting No.2 line parameter is 0.See page 17 DISP=13,NO.page 24 DISP=17,NO,Page 30 DISP=16 fig.in remote status mean No.4 way,No.1 way.No.3 way is make status,No.2 is break status. Switch output module's other one function is over limit alarm output.set electric parameter range,when in measure the electric parameter over set range,corresponding switch output port is make status,panel corresponding position show 1,when signal back in parameter range then show 0.

Meter inside's DOSI(3byte)is switch set register,through meter's communication port write to parameter,and come true alarm set,and also can direct through panel button to operation,to alarm object and alarm value to set.

8.2.4 programme example(see table 18)

To 10kV/100V,400A/5A's meter to set D01 is $U_a > 11kV$ alarm,DOS2 is $I_a > 400A$ alarm, DOS3 is $PF < 0.9$ alarm,DOS4 is $F > 51.00Hz$ alarm,the control word should write:

Table 18

Sort	Alarm condition	Control word(high byte at front)		
		BYTE2	BYTE1	BYTE0
switch output 1	$U_a > 11.00kV$	128+1=129	1100 (04H4CH)	
switch output 2	$I_a > 400A$	128+7=135	4000 (0FHA0H)	
switch output 3	$PF < 0.900$	21	900 (03H84H)	
switch output 4	$F > 50.00Hz$	128+26=154	5100 (13HECH)	

switch capacity set parameter DOSI also can through board's button to set programme,in programme operation,DOSI menu item parameter value is corresponding DOSI relative parameter(see table 19).In fig.8 alarm set:DO-1 mean set item is switch output module 1;0129 is select alarm energy item is U_a high alarm.6000 is alarm value,when $U_a > 6000(U_a > 600V)$,D01 output alarm signal,namely:relay is make.

Table 19

Item	switch capacity output item TYPE		Transmit output item TYPE
	Corresponding parameter(low alarm)	Corresponding parameter(high alarm)	Corresponding parameter(4-3bit)
Ua(A phase voltage)	1	129	129
Ub(B phase voltage)	2	130	130
Uc(C phase voltage)	3	131	131
Uab(AB wires voltage)	4	132	132
Ubc(BC wires voltage)	5	133	133
Uca(CA wires voltage)	6	134	134
Ia(A phase current)	7	135	135
Ib(B phase current)	8	136	136
Ic(C phase current)	9	137	137
Pa(A phase active power)	10	138	138

Pb(B phase active power)	11	139	139
Pc(C phase active power)	12	140	140
Ps(total phase active power)	13	141	141
Qa(A phase reactive power)	14	142	142
Qb(B phase reactive power)	15	143	143
Qc(C phase reactive power)	16	144	144
Qs(total reactive power)	17	145	145
PFa(A phase power factor)	18	146	146
PFb(B phase power factor)	19	147	147
PFc(C phase power factor)	20	148	148
PFs(total power factor)	21	149	149
Sa(A phase apparent power)	22	150	150
Sb(B phase apparent power)	23	151	151
Sc(C phase apparent power)	24	152	152
Ss(total apparent power)	25	153	153
F(frequency)	26	154	154
Voltage unbalancedness		155	155
Current unbalancedness		156	156
Linkage(closed)		157	
Linkage(Break)		158	
-Ps(two way active power)			159
-Qs(two way reactive power)			160
-F(two way frequency)			161
-PF(two way power factor)			162
Residual current)		163	163

Analog capacity leave factory default set:Analog capacity output according secondary current to count.
 No.1 way is A phase current:TYPE is 135,UAL is 5000;5000 corresponding secondary side current 5A
 No.2 way is B phase current:TYPE is 136,UAL is 5000;5000 corresponding secondary side current 5A
 No.3 way is C phase current:TYPE is 137,UAL is 5000;5000 corresponding secondary side current 5A
 No.4 way is A phase voltage:TYPE is 129,UAL is 3800;3800 corresponding secondary side voltage 380V
 Total active power:TYPE is 141,UAL is 300;3300 corresponding secondary power value is 3300W
 Total power factor:TYPE is 149,UAL is 1000;1000 corresponding secondary power factor value is 1.000
 Frequency:TYPE is 154,UAL is 5000;5000 corresponding secondary frequency value is 50.00Hz
 Notice:when TYPE set is 0000,mean "remote"status.

Menu explain:

(a)"-F" is frequency two way transmit, mean transmit frequency range $50 \pm x \text{ Hz}$, corresponding transmit output 0~10~20mA (or 4~12~20mA). For example set full scale value is 6000, it mean transmitted frequency range 40.00~50.00~60.00Hz) corresponding 0~10~20mA (or 4~12~20mA) transmit output.

(b)"-Ps(-Qs)" is active (reactive) power's two way transmit, can choose: 0~10~20mA (or: 4~12~20mA). Like three phase four wires, input signal is 380V 5A's meter. set power full scale value is 5700W. The transmit corresponding relative as follow: -5700W~0W~+5700W transmit is 0~10~20mA (or 4~12~20mA).

(c)"-PF" is two way power factor transmit, full scale value is 1000, mean power factor -1.0~+1 corresponding 0~10~20mA (or 4~12~20mA) transmit output.

9. Common problem and solution

9.1 About communication

1) Meter no back data

Ans:

First make ensure the meter's communication set message like slave address, baud rate, check out type if fit master PC requirement. If present some pieces meter communication can't back data, detect to present communication total wires's connection if correct and reliable, RS485 transfer is in normal. If only one piece or less meter communication in abnormal, also can check corresponding communication wires, and revised the abnormal and test normal meter slave PC's address, remove or confirm the master software problem, or through exchange abnormal and normal meter's installation position to test, remove or confirm meter fault.

2) Meter back the data is not exact

Ans:

This series digital multifunction network power meter's communication open to customer's date have one time net float type data and secondary net int/long type data. Please read careful in the communication address table list about data save address and save format's explain. make ensure to according corresponding data format change.

9.2 About U, I, P measure no exact

Ans:

First make sure the correct voltage and current signal already connect to meter. It can use multimeter to measure voltage signal, in necessary to use Power Clamp Meter to measure current signal. Second, make sure signal wire's connection is correct. Like current signal's same name port (also is input port), and each phase's phase sequence if have problem. This series product meter can observe power interface display, only in opposite transmitted electrical status, active power is negative, as usual status, active power symbol is positive, if power active symbol is negative, might current input wires incorrect connection, or maybe phase sequence incorrect also will result power display abnormal. Other should notice is meter display the power energy is first net value, if meter inside set's voltage current transformer multiple rate is different with practice use, also result no exact in meter energy display. The measurement range can't change after leaving factory.

Connect network can according present practice connection to revised, but programme menu's connection set must be same as practice, or else will result error display message.

9.3 About the energy move word no exact

Ans:

Meter's energy accumulating basic to measure the power, first observe meter's power value if accord with practice load. This series multifunction energy meter can support two way energy accumulation, under the incorrect connection condition, total active power is negative, energy accumulating to reverse active power. Forward active power can't accumulation. The most problem happen in practice use is current transformer input and output opposite connection. This series product both can see split phase with symbol's active power, if power is negative might is connection error, otherwise phase sequence connect wrong will result the move word of meter in abnormal.

9.4 Meter no light

Ans:

Make ensure fit auxiliary power (as per product practicality specification sticker) already additional meter's auxiliary power terminal. over the range, auxiliary power voltage will damage meter and can't resume. It can use the multimeter to measure auxiliary power's voltage value, if power voltage in normal, meter no any display, and can consider break then make again. If meter no normal display can contact our technical dep.

9.5 Meter no respond operation

Ans:

Press meter button “SET” “▶” “▶”m“▶” eter no respond,try to break then make again,meter can't resume in normal then contact our technical dept.

9.6 Other abnormal condition

Ans:

Please contact our technical in time.User can list detail description present condiction.